

Backflow Preventer Presentation

ASSE/ASPE Conference
New York City
May 2015

What is Backflow?

- Backflow is the undesirable reversal of flow of water or mixture of water and / or other substances into the distribution pipes of the potable supply of water from any source or sources
- Backflow can occur during conditions of backsiphonage or backpressure

Backflow Preventer Selection

- Backflow Selection should consider:
 - Level of Hazard
 - High or Low
 - Type of backflow protection
 - Backsiphonage
 - Backpressure
 - Approvals
 - Must have the correct approvals required by the authority having jurisdiction over the application.

Level of Hazard

High Hazard

- Health Hazard
- Contaminant
- Impairs water quality
- Causes sickness or death

Low Hazard

- Non-Health Hazard
- Pollutant
- Impairs water quality
- Will not cause sickness or death

Types of Backflow Preventer Assemblies

- Pressure Vacuum Breaker (PVB)
 - Only protects against backsiphonage
 - For high and low hazards
- Double Check Valve Assembly (DC)
 - For backsiphonage and backpressure
 - For low Hazards only
- Double Check Detector Assembly (DCDA)
 - For backsiphonage and backpressure
 - For low hazards only
- Reduced Pressure Principle Assembly (RP)
 - For backsiphonage and backpressure
 - For high and low hazards
- Reduced Pressure Principle Detector Assembly
 - For backsiphonage and backpressure
 - For high and low hazards

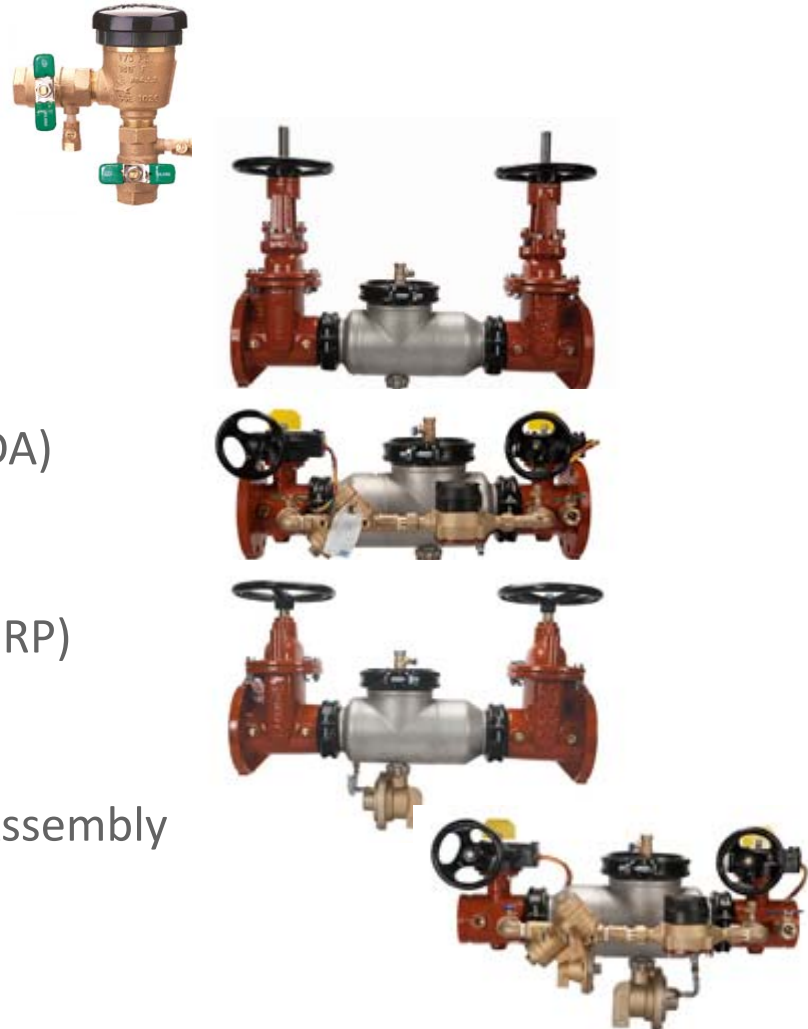

Backflow Approvals

- The Authority Having Jurisdiction defines product acceptability
 - Tend to specify highest level of protection for commercial applications
- Backflow approval agencies
 - USC, ASSE, UPC, CSA, AWWA, UL, FM
- **NYC DEP – accepts USC as their approval source**

Double Check (DC)

- Used in Plumbing, waterworks, and Irrigation systems
- Designed to prevent Pollution from flowing back into the city water system
- Manufactured in sizes 3/4" to 12"
- Must only be used when the potential for backflow is a low or non-health hazard



DC Operation – Static (No Flow)

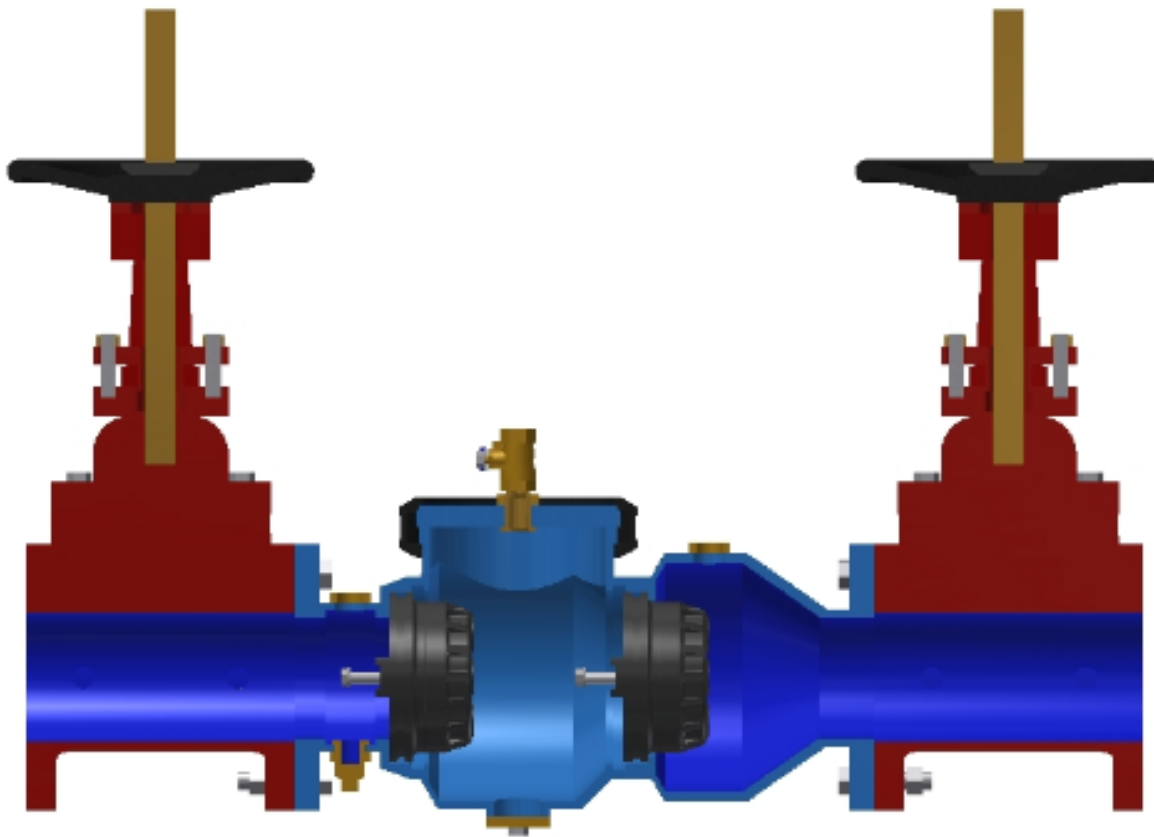

- Checks are in the closed position under static conditions
- Checks will also be closed during backpressure or backsiphonage conditions

DC Operation – Flowing

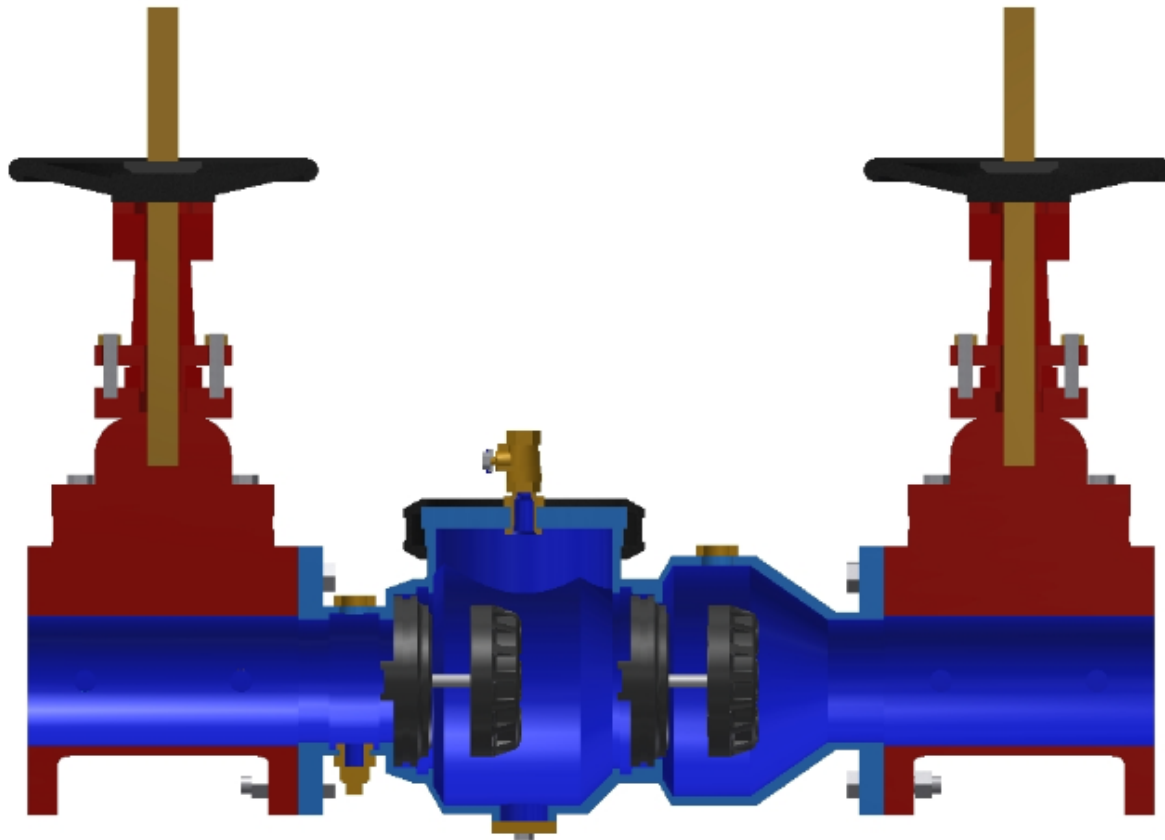

- Checks will begin to open when downstream pressure drops by about 4 pounds, inducing a flow

Detector Assemblies

- Types:
 - Double Check Detector Assemblies (DCDA)
 - Reduced Pressure Detector Assemblies (RPDA)
- Application:
 - Fire suppression systems (static condition)
- Purpose:
 - Detect small water usage, either unauthorized use or a leak in the system

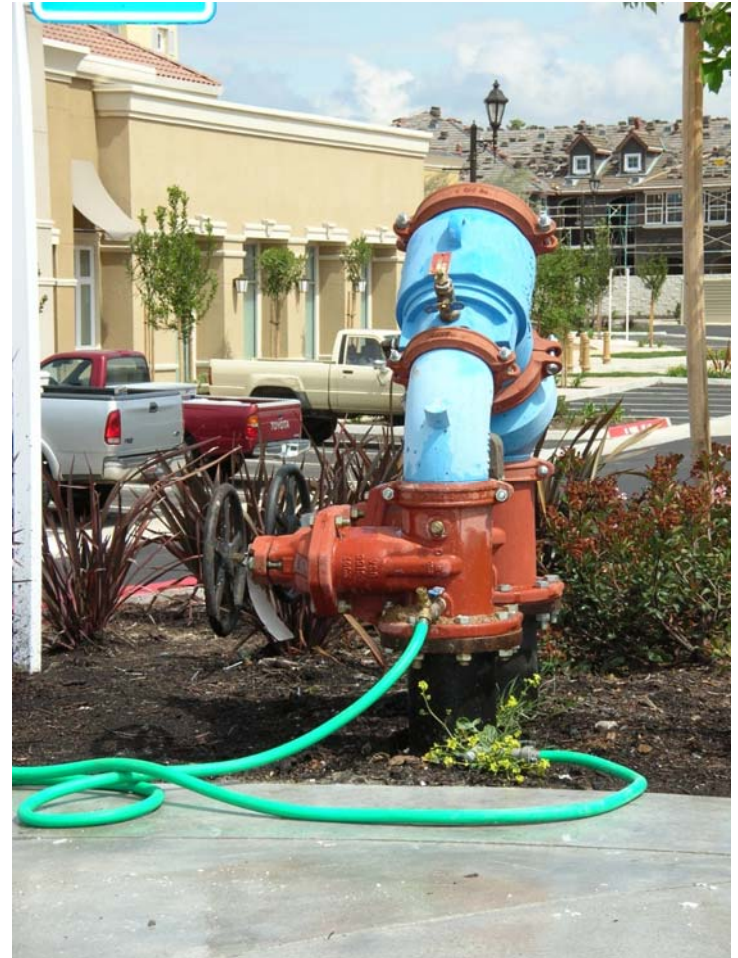

Why is a Detector Assembly used?

- Fire suppression systems typically do not have a mainline water meter installed
 - Mainline water meter would be costly
 - Mainline meter would typically sit static anyway
 - Mainline water meter will not accurately measure low flows
 - Do not want to put anything in the system that could impair flow or cause additional pressure loss

Detector Operation – Static (No Flow)

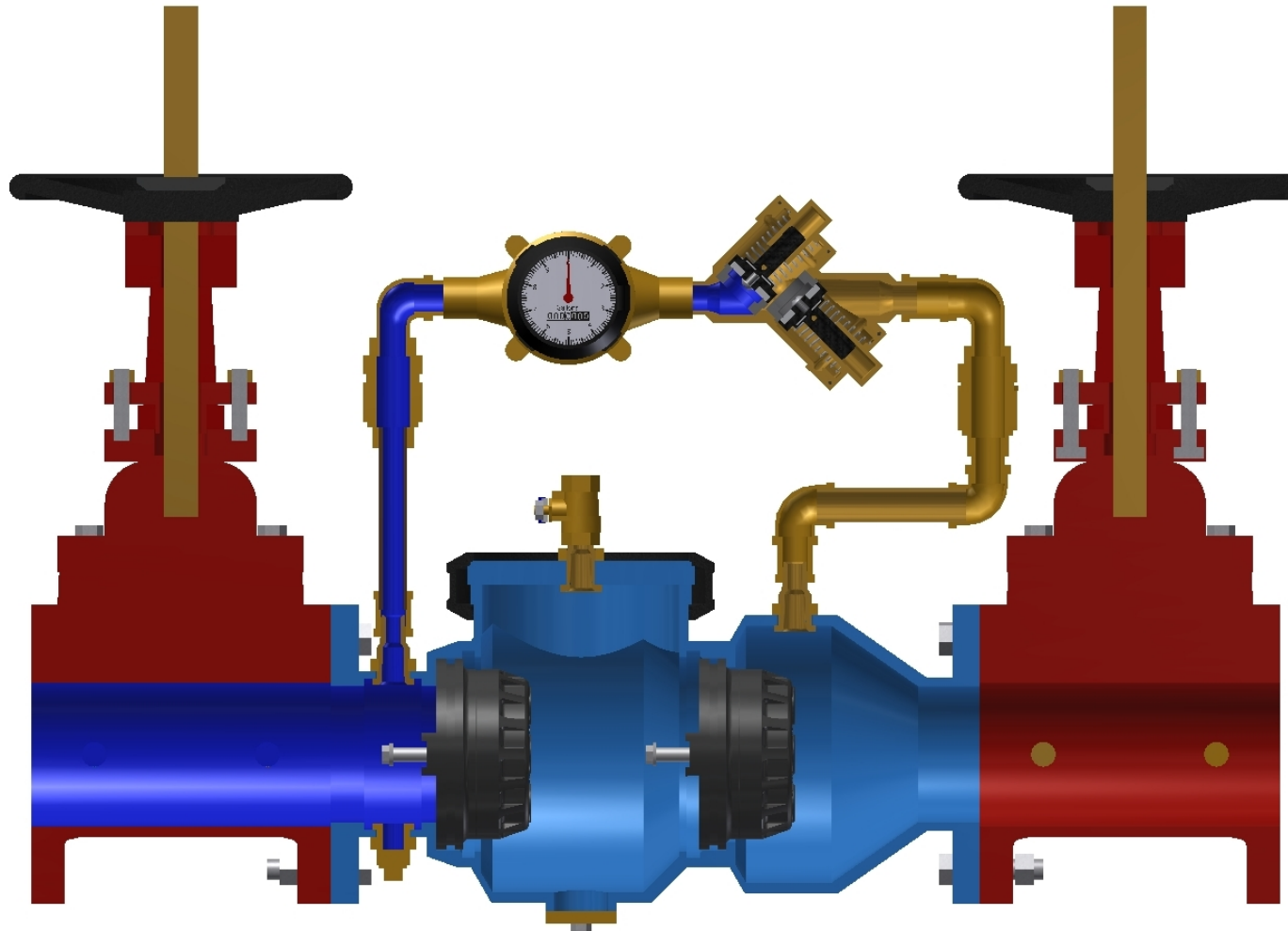

- Line-size checks in closed position
- Bypass checks in closed position
- Meter not moving or registering flow

Detector Operation – Low flow (≤ 2 GPM)

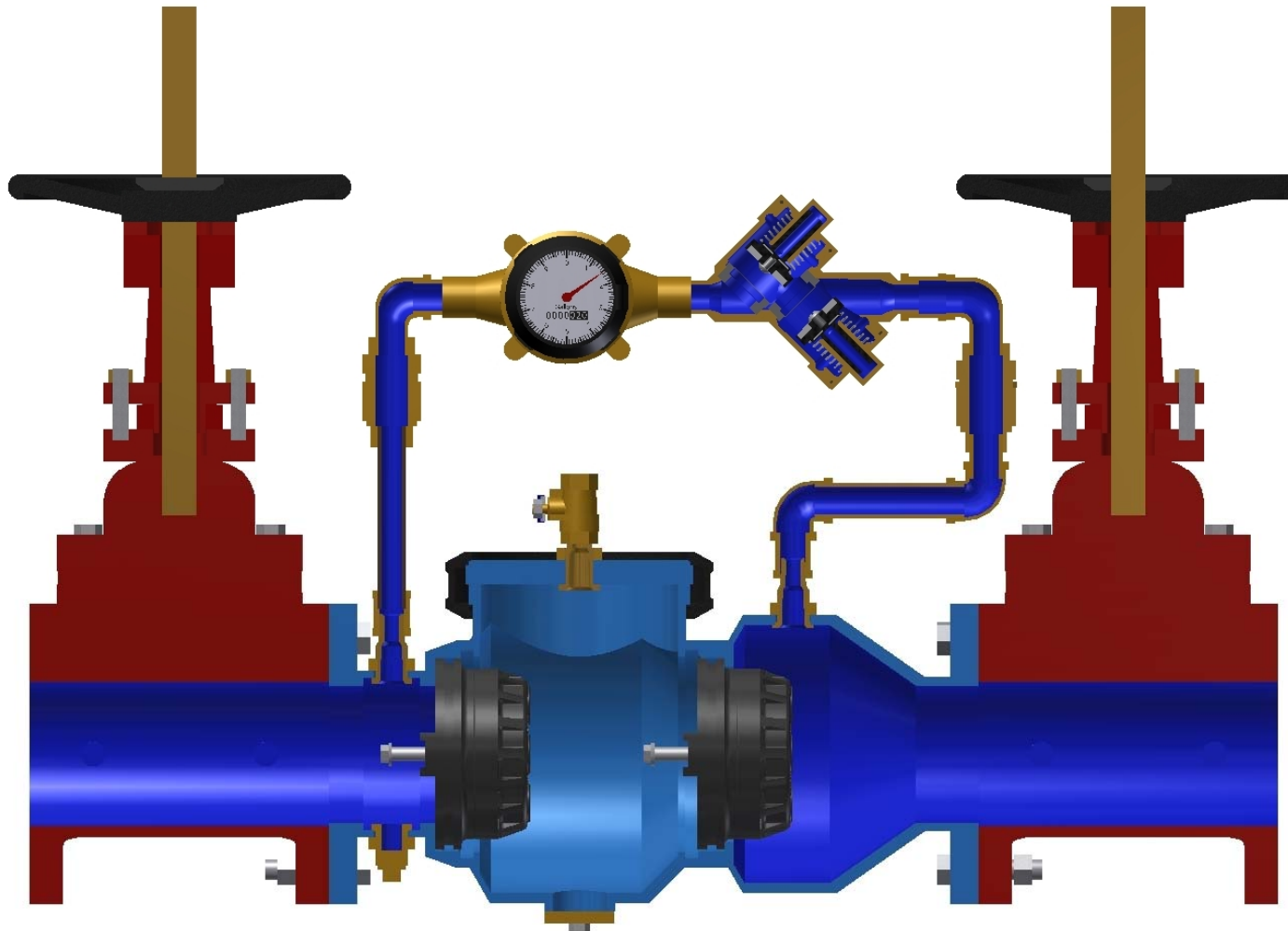

- Line-size checks in closed position
- Bypass checks in open position – 100% of flow through bypass
- Typically accomplished with stronger springs in line-size check(s)
- Meter accurately registering flow

Detector Operation — High flow (> 2 GPM)

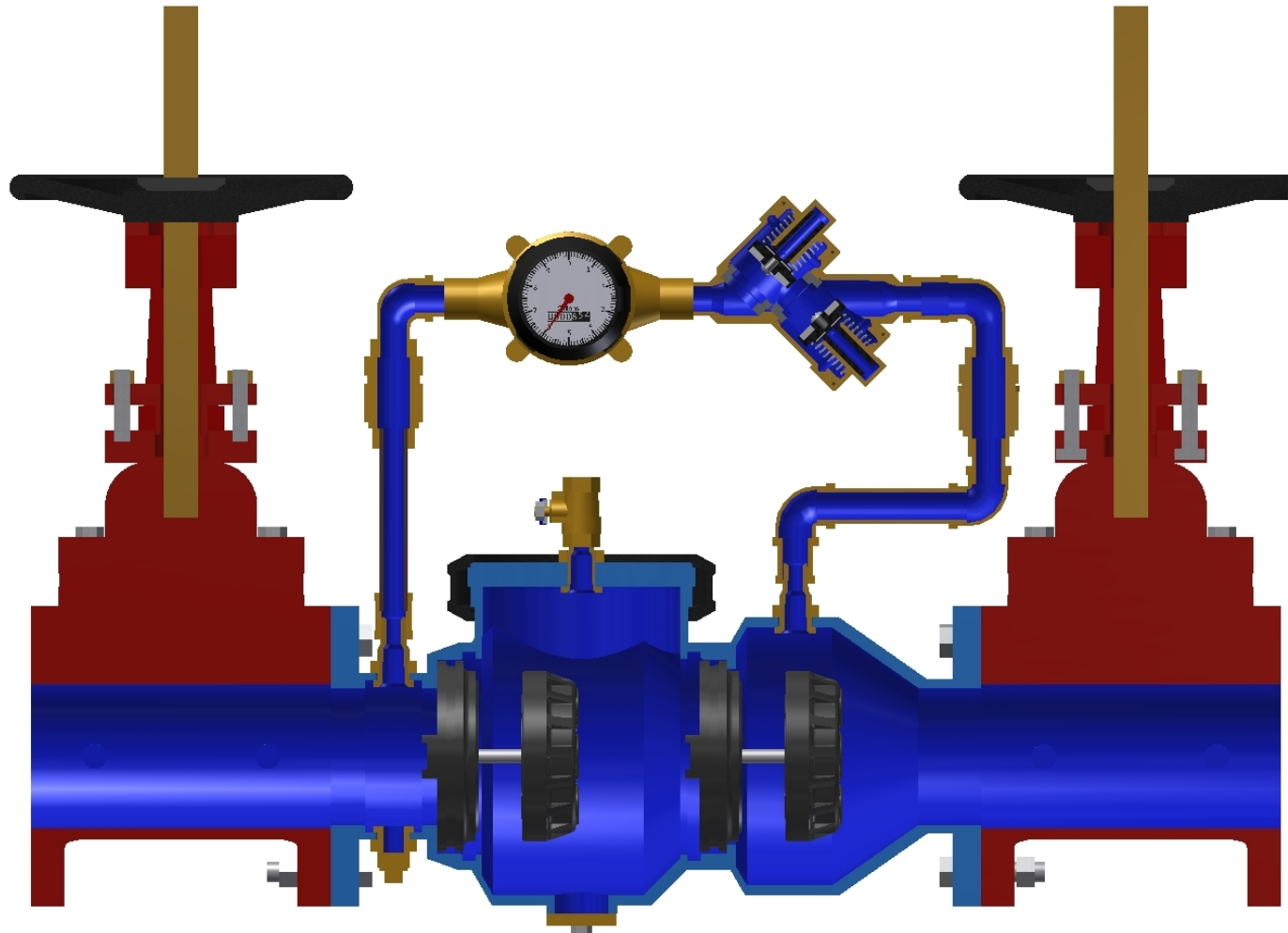

- Line-size checks in open position
- Bypass checks in open position
- Meter registering flow but not accurately

Reduced Pressure Principal (RP)

- Used in Plumbing, waterworks, and Irrigation systems
- Designed to prevent Contamination or Pollution from flowing back into the city water system
- Manufactured in pipe sizes ½” through 10”
- RP’s are the ultimate in backflow protection

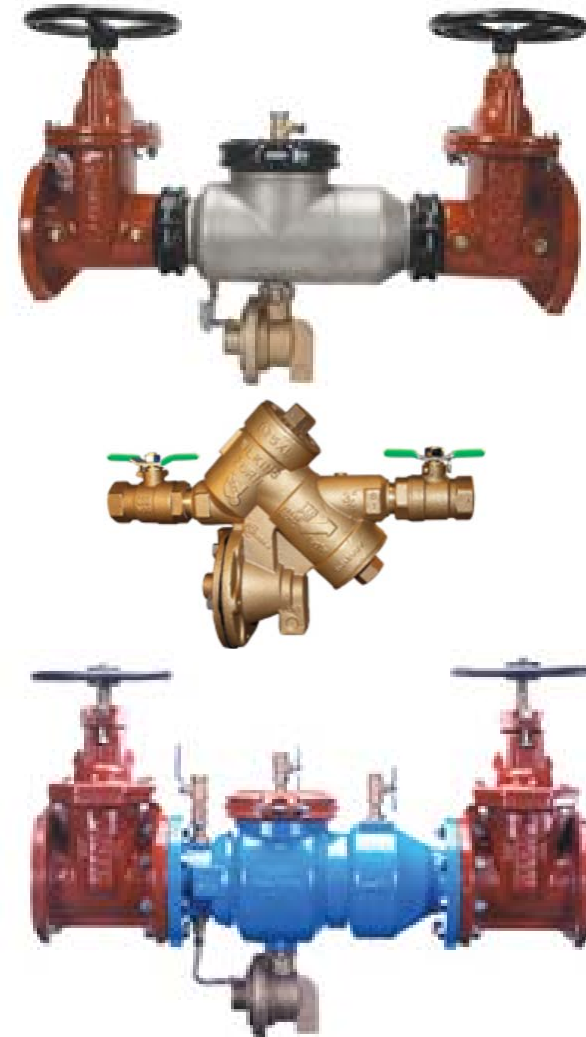

RP Operation - Static (No Flow)

Both Check Valves and the Relief Valve are in the closed position. The difference in color reflects the pressure drop across each Check Valve.

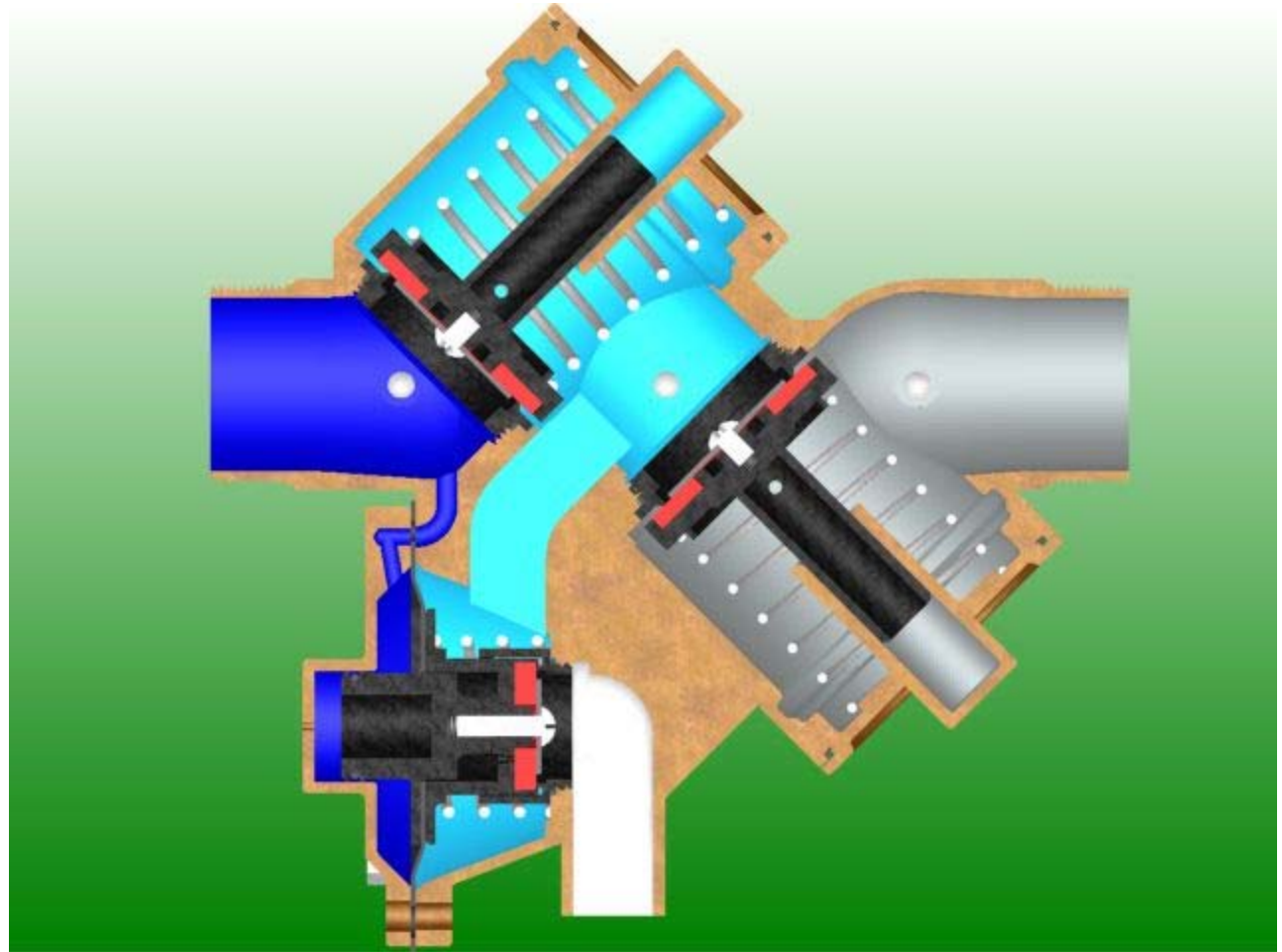

RP Operation - Normal Flow

Both Check Valves have lifted off of their seats, and the Relief Valve remains in the closed position.

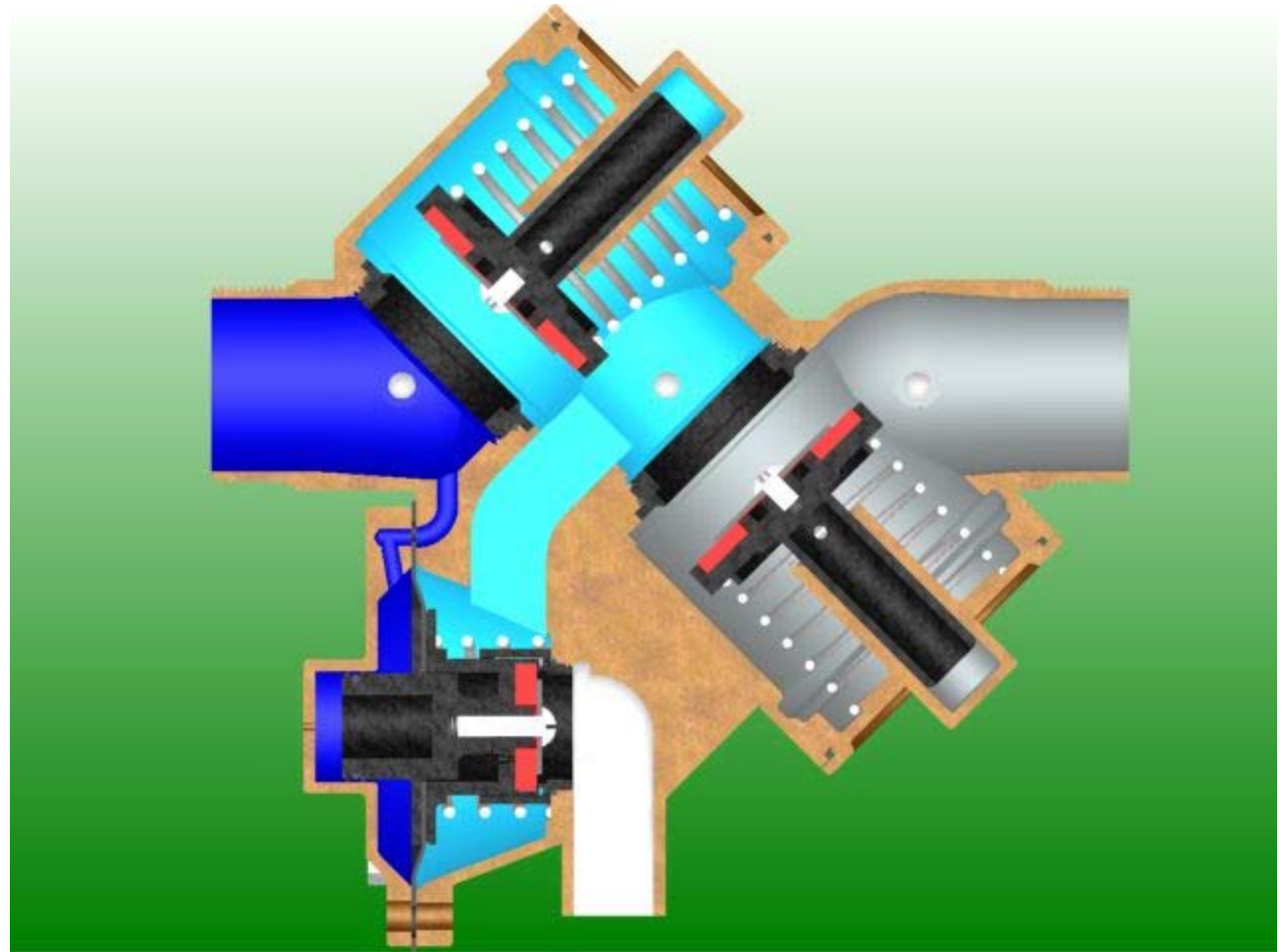

Static Condition with 1st Check Fouled

With the First Check Valve fouled, the pressure in the zone equals the inlet pressure, and the Relief Valve goes into the open position.

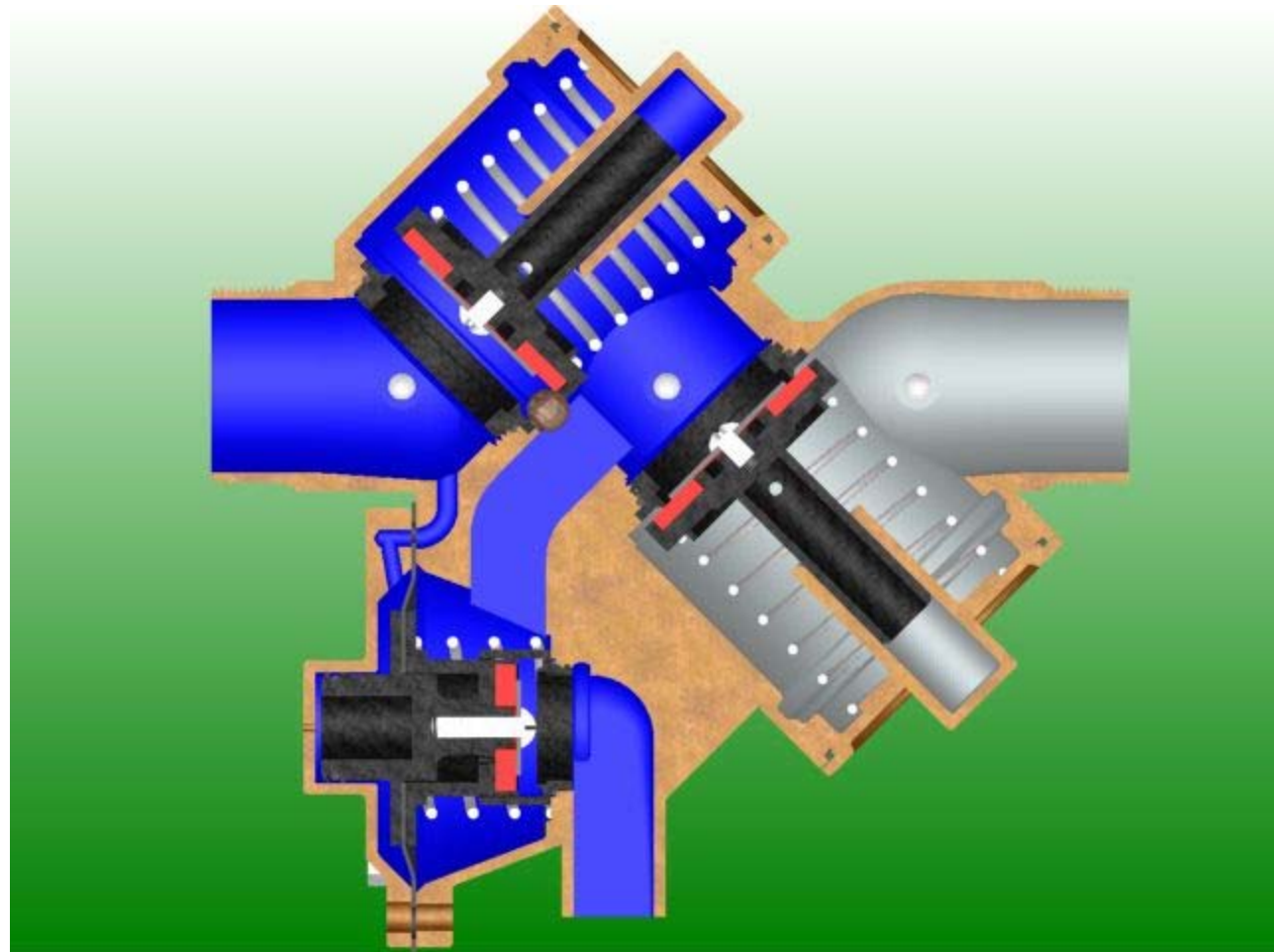

Backpressure with 2nd Check Fouled

With the Second Check Valve fouled, the downstream pressure, which is greater than the inlet pressure, moves into the zone and causes the Relief Valve to open.

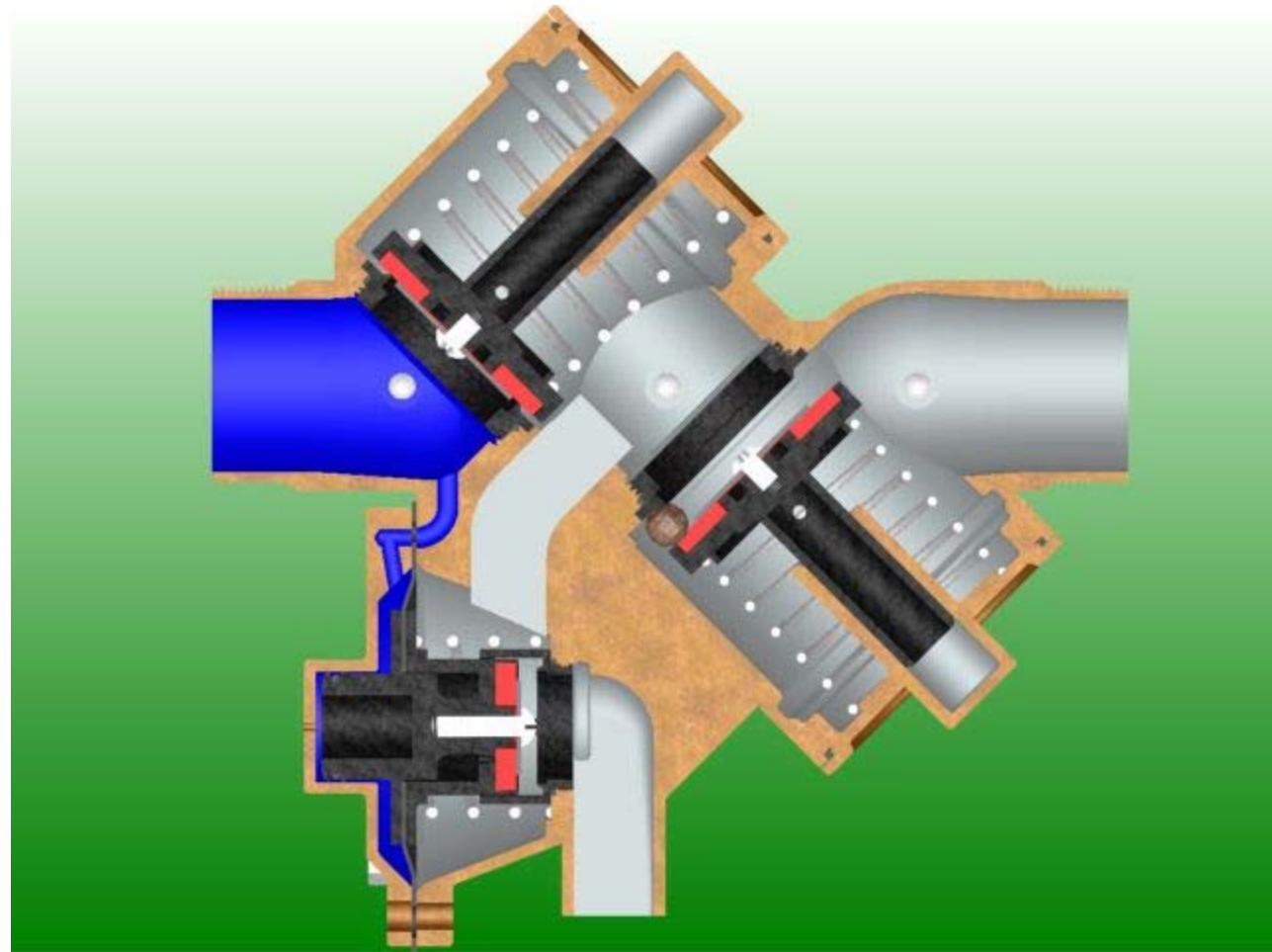

Backsiphonage with 2nd Check Fouled

With the Second Check Valve fouled, the downstream fluid will cause the relief valve to open because the inlet pressure has gone sub-atmospheric.

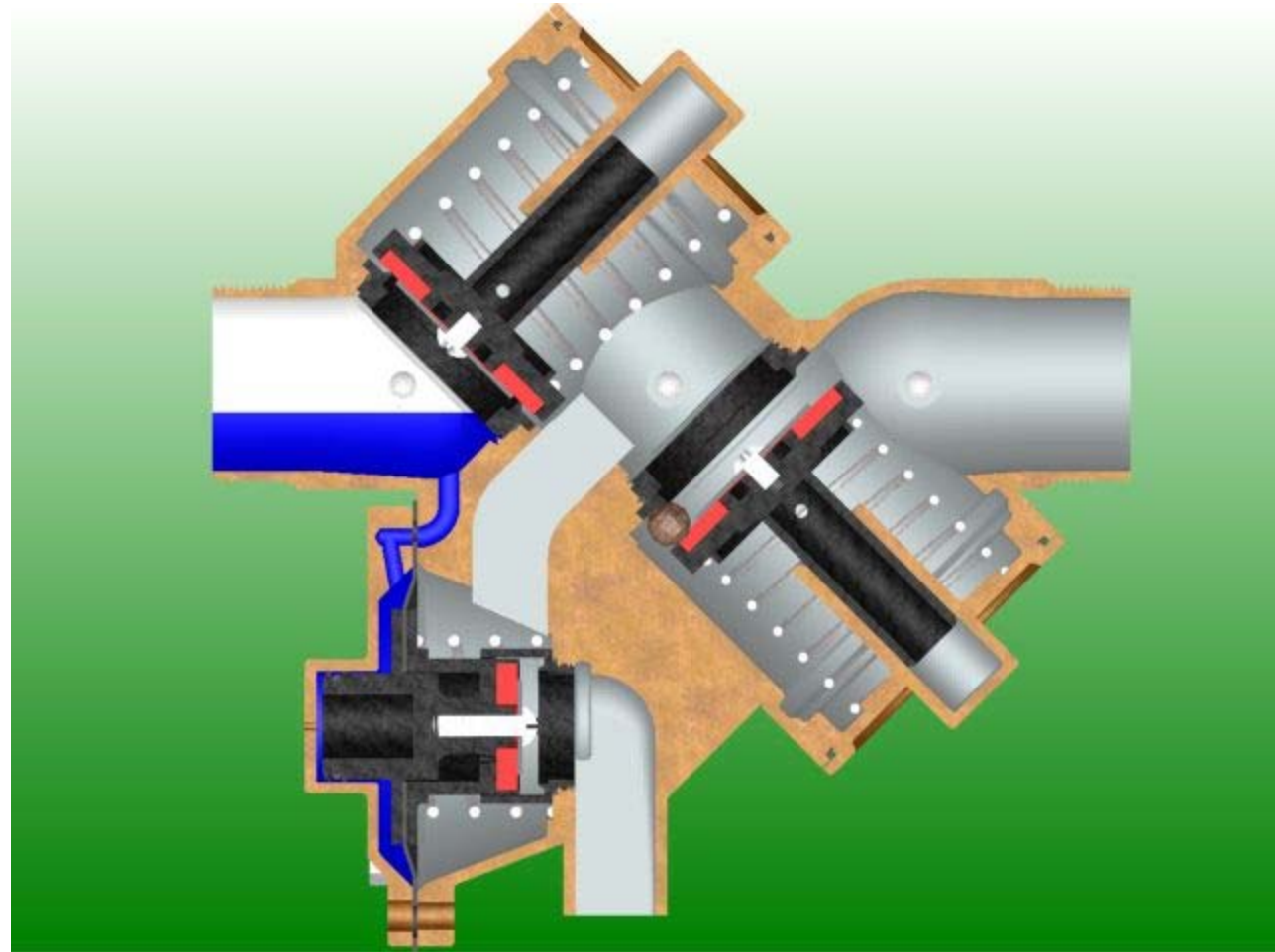

Flood Risk Associated with Indoor RP

Backflow Preventer Discharge

An 8" backflow preventer at 110psi can discharge more than 550gpm enough water to fill a 20' x 20' x 10' room in one hour (33,000 gallons)



Relief Valve Discharge Rates

Model 375, 475 & 975 RP & RPDA
Backflow Preventers

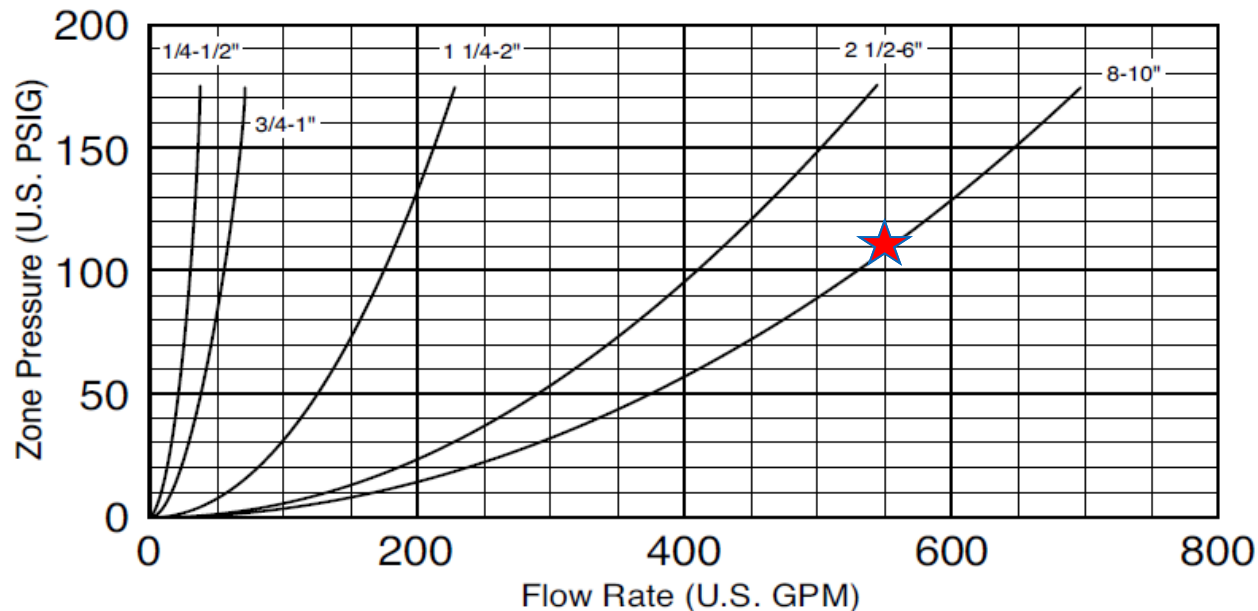

NYC – “8 Hour Rule”

- NYC – “8 Hour Rule”
 - A mechanical room must be able to withstand 8 hours or RP discharge and allow no more than 8 feet of water
- What if a dump condition happens over night?
- What is the cost of a flooded mechanical room?

New Flood Control Systems

- Automatically shuts down flow to the backflow in the event of relief valve discharge
- Configured in conjunction with a Backflow, ACV, discharge monitor switch and electronic solenoid timer to prevent damage to mechanical and electrical equipment in an indoor installation



Flood Control Operation – Normal Flowing Condition

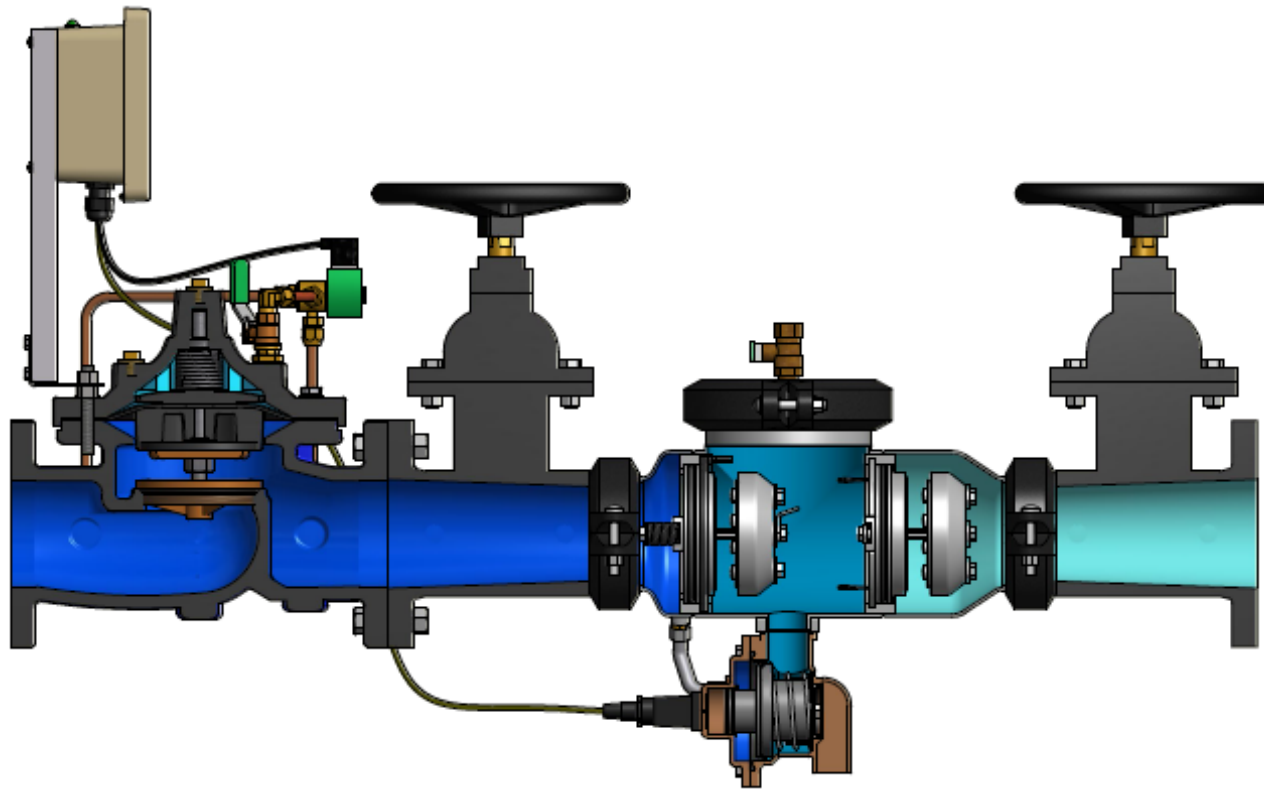

- Under normal operation both check valves are flowing, the ACV is fully open, and the relief valve is closed

Flood Control Operation – Static Condition, #1 Check Fouled

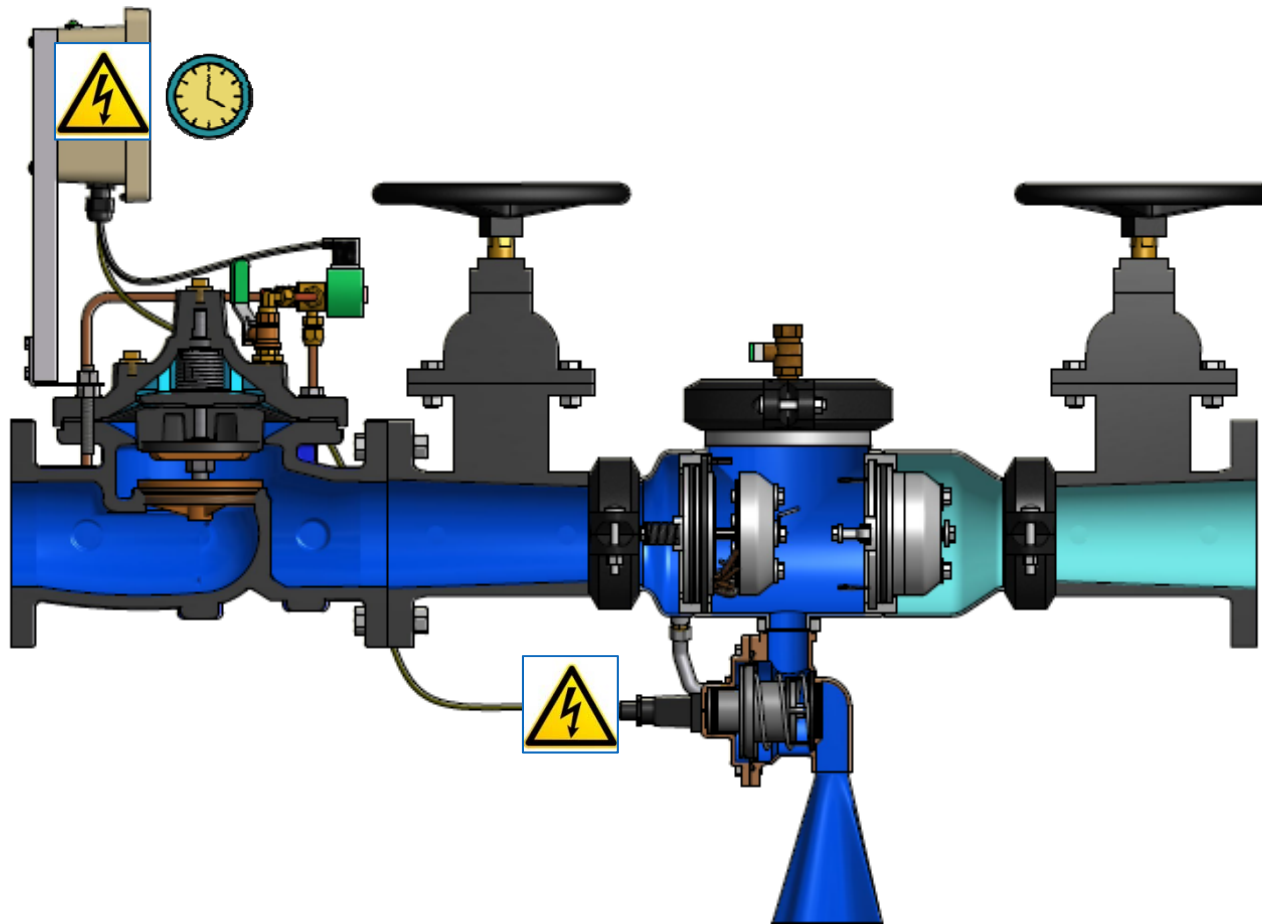

- In a static condition, with the first check fouled, the relief valve will begin to dump water.
 - An electrical signal is sent from the monitor switch to the electronic solenoid timer
 - The time delay in the solenoid timer will begin its countdown

Flood Control Operation – Water Shutdown

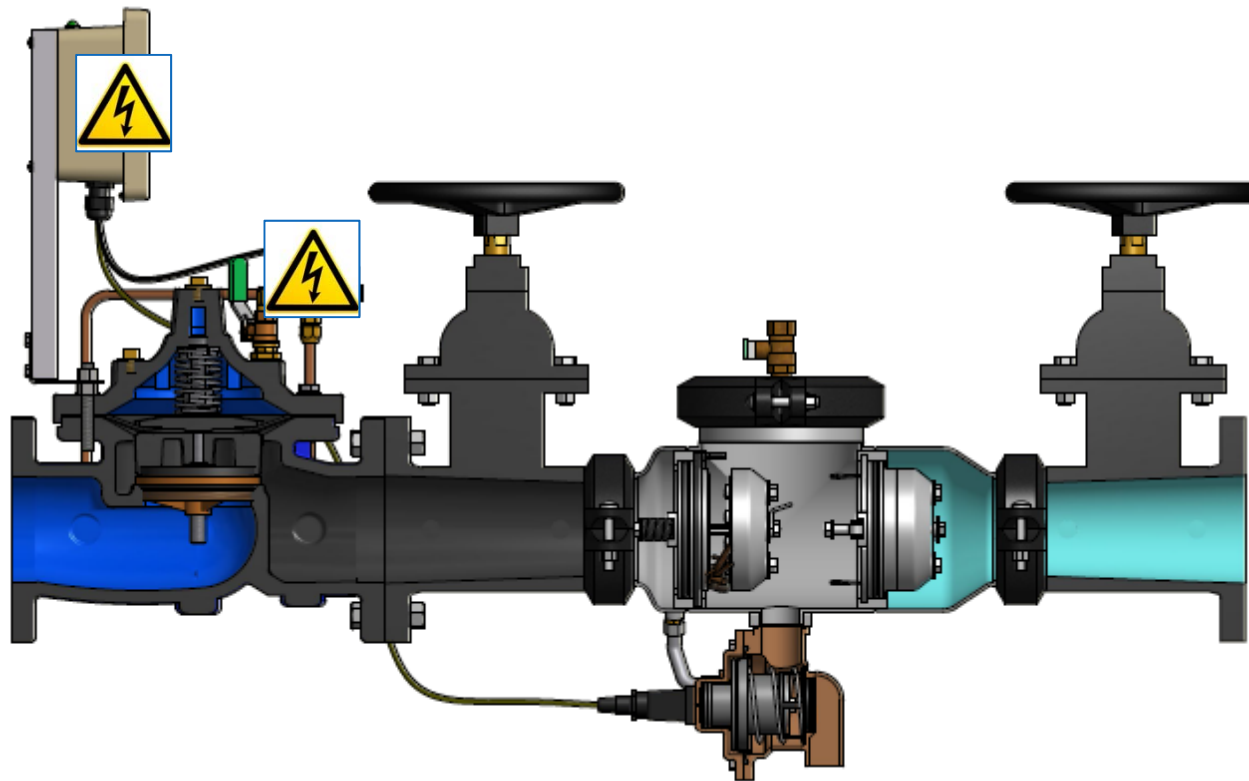

- Once the countdown has completed, the solenoid timer will send a signal to close the ACV
 - The solenoid timer sends an electric signal to close the solenoid in the ACV
 - The solenoid in the ACV shuts down flow through the valve, stopping the relief valve discharge
- The system can also be configured to send a signal to an alarm panel or pump relay

FCIS Applications

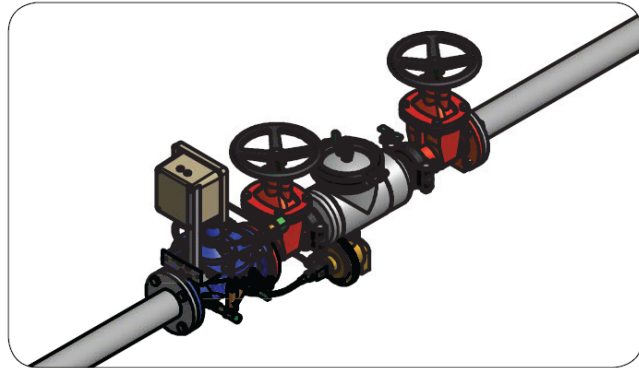

Standard System

- Single Solenoid Control Valve shuts down the water supply to the backflow preventer, preventing discharge of water from a fouled first check in the static condition.

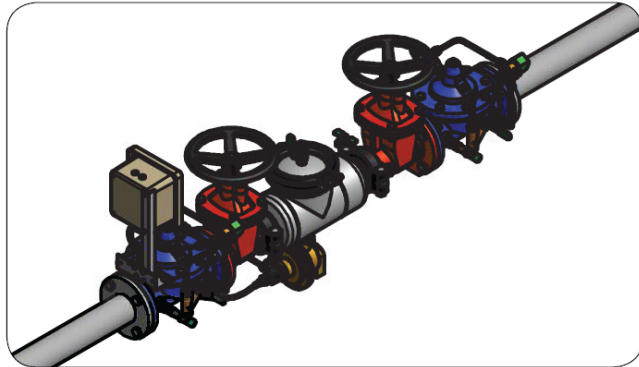

Isolation System

- Two Solenoid Control Valves isolate the Backflow Assembly on both the inlet and outlet, preventing discharge due to an additionally fouled second check.

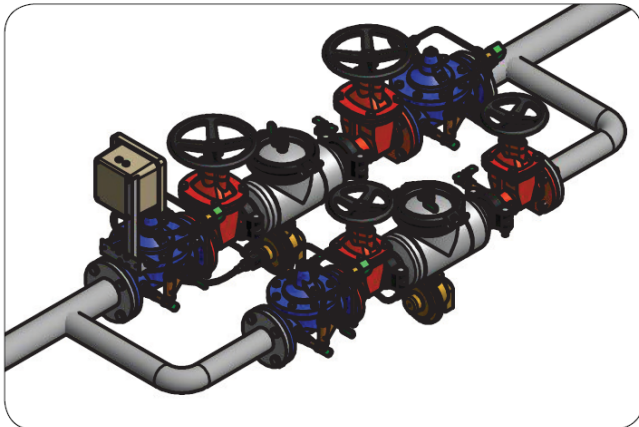

Critical Water Supply System

- A third Solenoid Control Valve will open to divert the water supply to a bypass line, providing continuous water supply to the facility.

Typical NYC Installations

“n” Pattern Solutions

- “n” pattern and vertical “z” pattern backflow are ideal for limited space requirements
- They are available in RP, DC, RPDA, and DCDA
- Function is exactly the same as traditional inline models
- They are gaining in popularity with specifiers and installers based on their small footprint



Vertical vs Horizontal Installations

- In-line RPs cannot be installed vertically
 - In a vertical installation not all water will drain from the number one check preventing the zone from fully draining
- “z” pattern vertical model RPs can be installed vertically because of the orientation of the checks and relief valve
- Double checks can be installed vertically if they have been tested and approved for this orientation



Retrofit Specific Solutions

- Pre-built backflow with custom length spools allow the installer to replace any lay length backflow with the shortest system downtime
- Shutoff Valves remain in the same location eliminating the need to rewire tamper switches or reconfigure security devices
- Available in Stainless Steel and Ductile Iron in DC, RP, DCDA, and RPDA
- This is the easiest way to replace an old model backflow with a newer design

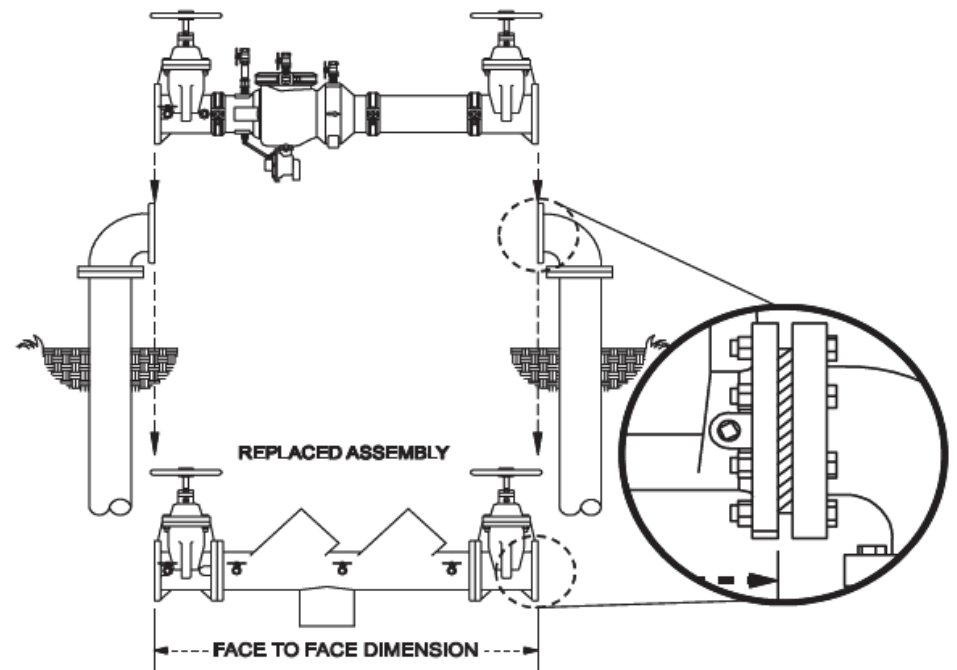

Thank you!

Questions?