



2025 - 2026 BOARD OF OFFICERS

President: Sean Mooney, CPD

Bard,Rao+Athanas Consulting Engineers, 100 Park Ave., Suite 200, NY, NY 10017
T: (212) 840-0060 E: SMOoney@brplusa.com

Vice President Technical: Joseph Tagliaferro, PE

Bard,Rao+Athanas Consulting Engineers, 100 Park Ave., Suite 200, NY, NY 10017
T: (646) 205 -7243 E: jtagliaferro@brplusa.com

Vice President Legislative: Esteban Roldan, PE, CPD

ARUP, 140 Broadway, NY, NY 10005
T: (212) 896-3000 E: esteban-c.rolدان@arup.com

Vice President Membership: Steve Ryback

Woods & Jaye Sales 33-09 37th Ave., LIC, NY 11101
T: (718) 786-8260 E: Steve.Ryback@WJNY.com

Treasurer: Salvatore S. Rachiele CPD

E: srachiele@optonline.net

Administrative Secretary: Daniel Blatto

Dellon Sales, 5 Albertson Ave, Albertson NY 11507
T: (516) 660-5582 E: danielblatto@dellonsales.com

Corresponding Secretary: Frank Wu, PE

Jaros, Baum & Bolles, 55 Water St., NY, NY 10041
T: (646) 810-2678 E: wuf@jbb.com

AYP Liaison: Dempsey Narcisse, CPD, EIT, ASSE 6060, LEED AP

Syska Hennessy Group, 1185 Avenue of the Americas, New York, NY 10036
T: (212) 556-3418 E: dnarcisse@syska.com

AYP Liaison: David Alperin, PE

Burns Engineering
T: (215) 608-7731 E: dalperin@burns-group.com

Women of ASPE Liaison Region 1: Catherine Filibes-Massih

Platsky Companies, 298 Montrose Road, Westbury, NY 11590
T: (914) 356-0407 E: cfmassih@platsky.com

Education Chair: Alberd Misku, CPD

Loring Consulting Engineers, Inc.
T: (212) 563-7400 E: amisku@loringengineers.com

Social Chair: Sasha Fernandez

Dellon Sales, 5 Albertson Ave, Albertson NY 11507
T: (516) 592-3293 E: sashaf@dellonsales.com

ASPE/ASSE & Affiliate Liaison: Steve Ryback

T: (718) 786-8260 E: Steve.Ryback@WJNY.com

Newsletter Editor & Webmaster: Robb A Risani, PE, CPD

E: robb.risani@arup.com E: nycaspenewsletter@gmail.com

ASPE NEW YORK CITY CHAPTER

PO BOX 293, GRAND CENTRAL STATION, NY, NY 10163

<http://www.aspenyc.org>

**FEBRUARY
MEETING
INFORMATION**

Topic: Next Generation Water Conservation Technologies

Speaker: Jonathan Farr

Sponser: Epic Cleantec

PDH CREDITS PROVIDED

Date: February 4th, 2026

Location: The Tailor Public House & Kitchen - 505 8th Avenue

[Virtual \(No PDH's\)](#)

Time: Dinner Served: 5:30pm

Technical: 5:30-6:30pm

Social: 6:30-8:00pm



If you wish to receive only digital copies of the newsletter please email nycaspenewsletter@gmail.com.

The ASPE NEWS is a publication of the New York City Chapter of the American Society of Plumbing Engineers. The Society or Chapter assumes no responsibility for any advertisements, statements by any officer or member which may be construed as an approval or disapproval, or official position of the Society, of the material contained herein. Local Chapters are not authorized to speak for the Society.

A Message

FROM THE PRESIDENT



My fellow ASPE NYC Members,

We're off to a wonderful start in 2026 with another well-attended meeting! The weather may be cold, but the meetings are always a great place to warm your heart with camaraderie, food, and engaging discussions. Be sure to bring your coworkers to spread the joy of ASPE!

In addition to our meetings, Engineer's Week is also a great time to spread the joy of ASPE and Engineering as a whole. This year, Engineer's Week runs from Sunday, February 22nd to Saturday, February 28th; this time is an opportunity to recognize those in the Engineering community that inspire the next generation of Engineers. **The Board would like to honor those in our ASPE family that are contributing to shaping the minds of young soon-to-be Engineers!** During the last week of February, we encourage you to get involved in promoting Engineering. Whether you participate an office/classroom visit, volunteer at a school/religious/community event, or just spend time with family members on a STEM activity, we want to hear about it! Send in your E-Week photos to ny.aspe@gmail.com, and you'll be featured in our next newsletter. **One lucky participant will also win an Amazon gift card!** So be sure to get out there and promote the Engineering discipline to younger generations!

This year, ASPE's ASSE 6060 MedGas Workshop will be held in our own backyard! From March 23rd to 26th, registrants will have 32 hours of instruction with team-based, hands-on activities at the Viega Experience Center in Long Island City. For more information, please visit <https://aspe.org/medgas-workshop/> or contact medgas@aspe.org.

Later in the year, ASPE heads to Oklahoma City for our bi-annual Convention and Expo! Mark your calendars for October 8th to 14th, as this event is a great way for members to learn about products in the industry, network with peers, and earn CEUs. Visit <https://expo.aspe.org/> for more information!

As our chapter continues to host appealing events and AI becomes more advanced, it's important to stay vigilant of phishing scams and remember the contact information for our board. **Board members will only reach out to you via the emails/phones listed on the cover sheet**, and official chapter communications will only come from ny.aspe@gmail.com, nycaspenewsletter@gmail.com, or postmaster@mg.aspenyc.org. We are thankful to have such an engaged chapter, and we appreciate your diligence to keep it safe!

We look forward to seeing you all our next Chapter Meeting on February 4th! Same great time, same great place.

Yours in ASPE,
Sean Mooney, CPD





MedGas Workshop

American Society of Plumbing Engineers



March 23–26, 2026

Hosted by Viega
New York City (Queens)



ASPE's MedGas Workshop fulfills the training requirements for the ASSE 6060: Medical Gas Systems Designer professional certification. By attending, you will enjoy all of the benefits of our 32-hour in-person experience, which include:

- Personal interaction with our expert instructor, Mark Allen
- Team-based, hands-on activities
- Practical design exercises with calculation examples
- ASSE 6060 practice exam
- Copy of NFPA 99-2024: Health Care Facilities Code
- Quizzes to test knowledge retention
- Calculator and supplies for hands-on exercises
- Lunch, drinks, and snacks each day
- 1.2 ASPE CEUs



Third-party testing will be available through Sherman Engineering after the workshop on March 27. If you would like to sit for the exam, please contact Nikita Patel, PE, ASSE 6060, at npatel@shermanengineering.com or 570-899-9090.

"The knowledge provided was phenomenal, and I would argue you would be hard pressed to find a better seminar on medical gas."

Register at ASPE Education:



Pure Freude
an Wasser



FLAWLESSLY DESIGNED TO MAKE EVERY INSTALLATION EASIER

GROHSAFE™ 3.0 PRESSURE BALANCE VALVES

Introducing GrohSafe™ 3.0 valves, designed to accommodate every situation with:

- One simplified pressure balance platform
- Simple, easy installation
- Enhanced features

With its compact body, flat back and multiple connections options, it offers unmatched versatility on the job. Discover more at grohe.us/grohsafe

ADDITIONAL CONNECTIONS



1/2" PEX crimp inlets



1/2" PEX cold expansion inlets

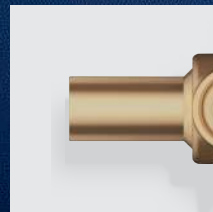

1/2" Stub-out inlets/outlets



1/2" CPVC inlets

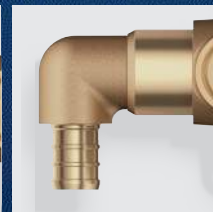

1/2" PEX crimp elbow inlets



1/2" PEX cold expansion elbow inlets

American
Standard

DXV



PART OF LIXIL

Michael Ford
Leader, Engineers & Commercial Plumber
Mechanical
732-628-6367
michael.ford@lixil.com

The Statue of Liberty is depicted in a grayscale, slightly desaturated style. She is holding a large, black industrial pipe in her right hand. The pipe has white text on it: "USA CH" and "PIPE". The background is a faded, high-angle view of the New York City skyline, with various skyscrapers visible. The overall aesthetic is industrial and gritty.

NEW YORK CAST IRON CITY

Thanks for turning to black and red for decades. We're proud to be part of your incredible city. Without you, NYC wouldn't be the same, and neither would we.

CHARLOTTE
PIPE AND FOUNDRY COMPANY

Built to be the Best®

BRADFORD WHITE®
WATER HEATERS

Residential and Commercial Water Heaters
to meet any industry need

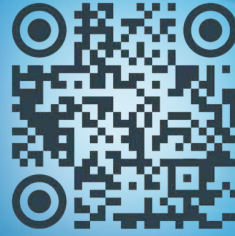

Balancing Valve Solutions

MANUAL | AUTOMATIC | THERMOSTATIC



Rich-Tomkins Company
Phone: 610-859-3552
Email: info@richtomkins.com

RELIABILITY & STRENGTH.



AMERICA'S MOST TRUSTED,
HIGH-PERFORMANCE,
HEAVY-DUTY COUPLING.

Engineered to provide superior
performance. Trust the proven leader.
Choose Husky.



SCAN TO CONTACT
ANACO TEAM

THERE'S ONLY ONE CHOICE

ChooseHusky.com ▪ (951) 372-2732

Specify ProSentry's wireless threat detectors today and start saving your clients money tomorrow.

Reduce risk and insurance premiums with:

All in one intuitive platform with live operator calls
Environmental and mechanical monitoring

Wireless valves from 3/4" to 10"
Sensors for water, oil and gas leaks



Portfolio-Wide Management



Gateway Transmitter



Water Leak Detector w/
Low Temp & Humidity



Water & Oil Leak
Detector w/ Low Temp



Smart Gas Detector



Boiler & Steam
Trap Temp



Door Ajar, Humidity,
Motion Detector



Mousetrap



Remote Control Outlet



Automatic Valves



Fluid Level Detector



Water & Oil Leak
Detector w/ Low Temp



Terrace & Roof
Leak Detector

For catalogue, draft specs, or a presentation:

212-244-4882 | Info@ProSentry.com | ProSentry.com



New! EQ[®] Arc

The 4-1/2" Compact, Turbine-Powered Touchless Faucet

**CHICAGO
FAUCETS**
Geberit Group



Proven Performance in a Sleek Design

- Integrated Certified ASSE 1070 Valve
- Sustainable Water Turbine Power Option
- Intuitive Responsive Sensor in the Spout
- Easy Install with Compact Control Box
- Durable Solid Brass Construction



www.chicagofaucets.com

**EDWARDS
& PLATT
DEELY**
631/253-0600

Represented by

dellon
Dellon Sales Company

Represented by

ELKAY
PRO FILTRATION

Up to

64,000

**BOTTLES SAVED* with just
1x NEW 10,000 Gallon Filter**

*** 20-ounce plastic water bottles**

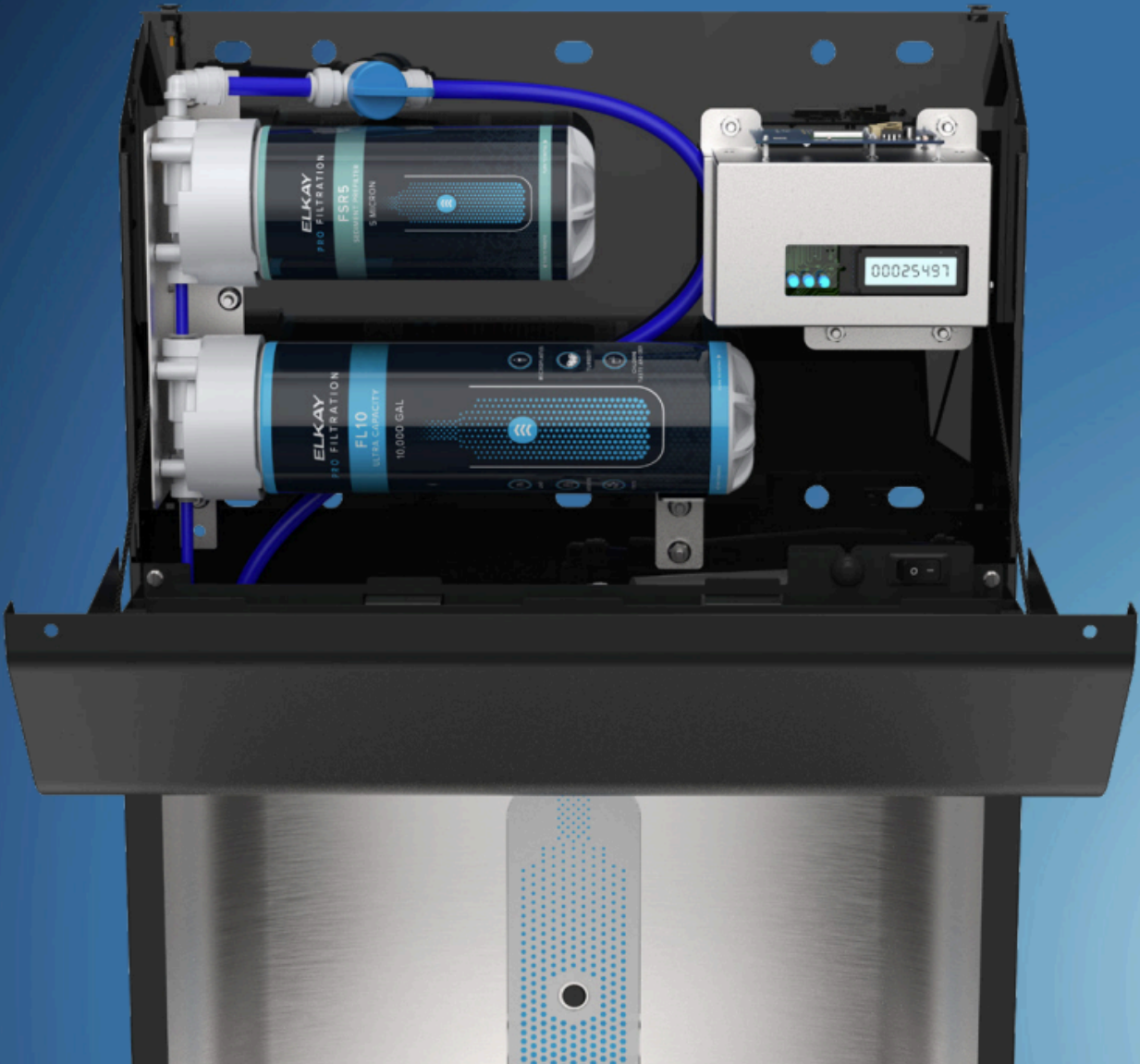



T&S has your **plumbing** solutions.

Discover the lasting reliability of T&S. From hose reels to sensor faucets, lab equipment to high-end fixtures, T&S offers all the plumbing products you need, with reliability built in. Contact your representative today to learn how T&S can outfit any facility, or visit tsbrass.com.



T&S plumbing products represented in New York by: Woods & Jaye Sales Co. Inc. - 718-786-8260

Temperature Control AND High Temperature Safeguard! "... And the two shall be as ONE."

A safe, reliable hot water system is a marriage between mechanical components and a control system with built-in safeguard protection. The ETV-Plus includes everything you need:

- 3-Way Stainless Steel Electronic Tempering Valve and Actuator that meets the California lead-free standards.
- Temperature Monitoring Control- High Temperature Safeguard with Solenoid Valve
- Remote Communication capability via Internet or BACnet

Safety that Endures

When the mixing valve sensor detects an overly high supply water temperature, the ETV-Plus signals the solenoid valve located in the hot water supply line to close, shutting off hot water supply to the system. It also triggers an alarm to notify personal and enacts a manual reset requirement so that the valve will not re-open until the problem is resolved.



With remote communications capability (via the Internet or BACnet) these alarms and other control points can be seen and accessed via the internet or an energy Management System.

These interactive components build a foundation for long-term safety.



PLUMBING
TECHNICAL SERVICES



NOTHING PROTECTS LIKE GRAY



Hari Patel
Regional Manager
Technical Services
570.899.9413
hari.patel@mcwanepbgrp.com



Upgrade your system from dry to preaction...



The Valve & System Configurator makes it a breeze to build out your system riser. Check it out by scanning the QR code, or visiting valveconfig.vikingcorp.com.

Data centers never stop evolving and your fire protection shouldn't either. Viking's new cULus Listed Data Center Upgradeable System delivers a smarter, simpler path forward. Install today as a dry pipe system, then upgrade to preaction when the need arises without costly rework or wasted investment.

By lowering upfront costs and simplifying future transitions, this system gives contractors and building owners the confidence that their protection will keep pace with the demands of modern infrastructure.

Learn more on our website at vikinggroupinc.com.

Remove



Install





BEACONMEDAES®

Welcome to BeaconMedaes

Within the medical gas market, we specialize in medical air and vacuum systems, manifolds, monitoring equipment and pipeline components. We assist our customers with exceptional technical support and customer service to maintain our name as one of the world's largest medical gas service providers.



Life is in the details.®



CONTACTS: JAY.DAGOSTINO@BEACONMEDAES.COM & CRAIG.RANALLI@BEACONMEDAES.COM



ARE YOU RESPONSIBLE FOR DESIGNING COMPRESSED GAS & VACUUM SYSTEMS?



ASSE 6060 MEDICAL GAS DESIGNERS

Sherman Engineering is excited to offer an upcoming ASSE 6060 Medical Gas Designer Renewal AND new Certification Exam. Please join us on Friday, March 27, 2026 at the Viega Experience Center.

RENEWAL EXAM

The renewal will include instruction by Mark Allen via MS Teams followed by an exam.

QUESTIONS?
CONTACT US:

Nikita Patel, PE, ASSE 6060
npatel@shermanengineering.com
570-899-9090

01

Growing Healthcare Industry

The healthcare industry is growing rapidly and designing a facility that meets code requirements and owner preferences will be made easier after completion of this course.

02

Code Requirements

The ASSE 6060 is now one of the approved credentials for medical gas designers responsible for sizing systems, their selection, layout, and more.

03

Engaging the Facility AHJ

This course helps you navigate conversations with the facility AHJ to make informed design decisions..

04

Professional Growth

With this credential, you can seamlessly transition into medical gas design with minimal support from supervisors.

05

Credential

This exam will be proctored by MGTC.

Scan the QR Code to sign up for your exam today!



SPECIFY THE BRANDS YOU TRUST.



Design Consultation



Specification Development



PDH & CEU Training



Startup & Warranty Assistance



Support From Inception to Completion



BOSCH



ASC
Engineered Solutions

CHARLOTTE
PIPE AND FOUNDRY COMPANY



MIFAB



AMTROL



BrassCraft



GRUVLOK
An ASC Engineered Solution

FLEXHEAD
An ASC Engineered Solution

EPC | Elkhart Press
Copper

aquatherm



cimberio

ELECTROSTEEL
USA

LittleGIANT

ONSIS

SYMMONS



MISSION
RUBBER COMPANY



elster

EASYHEAT

Watson McDaniel



Scan to Earn CEU Credits in Person or Through Live Webinars with our Industry-Leading Experts.

CONTACT US

Quoting & Specification Information & Assistance



SPRINKLER FITTING SYSTEMS



FLEX TO FIT YOUR NEEDS

SERIES VS2 STANDARD COVERAGE SPRINKLER

The only flexible, UL Listed K5.6 Standard Coverage sprinkler enabling no equivalent length calculations past the branch line.

- ✓ Built to simplify or eliminate hydraulic calculations
- ✓ One assembly with one field connection
- ✓ Reduced pipe preparation and field work

| K5.6 | Quick & Standard Response

© 2024 VICTAULIC COMPANY. ALL RIGHTS RESERVED.

SCAN TO
LEARN MORE





SUPERIOR PROTECTION AGAINST SCALDING

REGULATORY AND ORGANIZATIONAL COMPLIANCE

INDUSTRY-LEADING SUSTAINABILITY

BEST-IN-CLASS INFECTION CONTROL



THE SUCCESS OF YOUR WATER MANAGEMENT PLAN BEGINS HERE

From the company that introduced digital hot water control to the world comes the only truly digital solution for safe, healthy domestic hot water.

Exclusively from Armstrong, ArmadaSM is one solution that does it all. ArmadaSM combines the power of Armstrong's exhaustive knowledge and expertise with our industry-leading hot water technology, tools and software to address the critical elements of your water management plan.

Armstrong's products are designed to work together or individually, allowing us the flexibility to engineer every ArmadaSM solution to meet the toughest requirements.

Find your digital solution for healthy hot water at: armstronginternational.com/armada

Keith Fricke
Keith@leonardpowers.com
Direct: (212) 584-4240
Main: (212) 244-8878



Leonard Powers^{INC}



SLOAN
Water Connects Us®

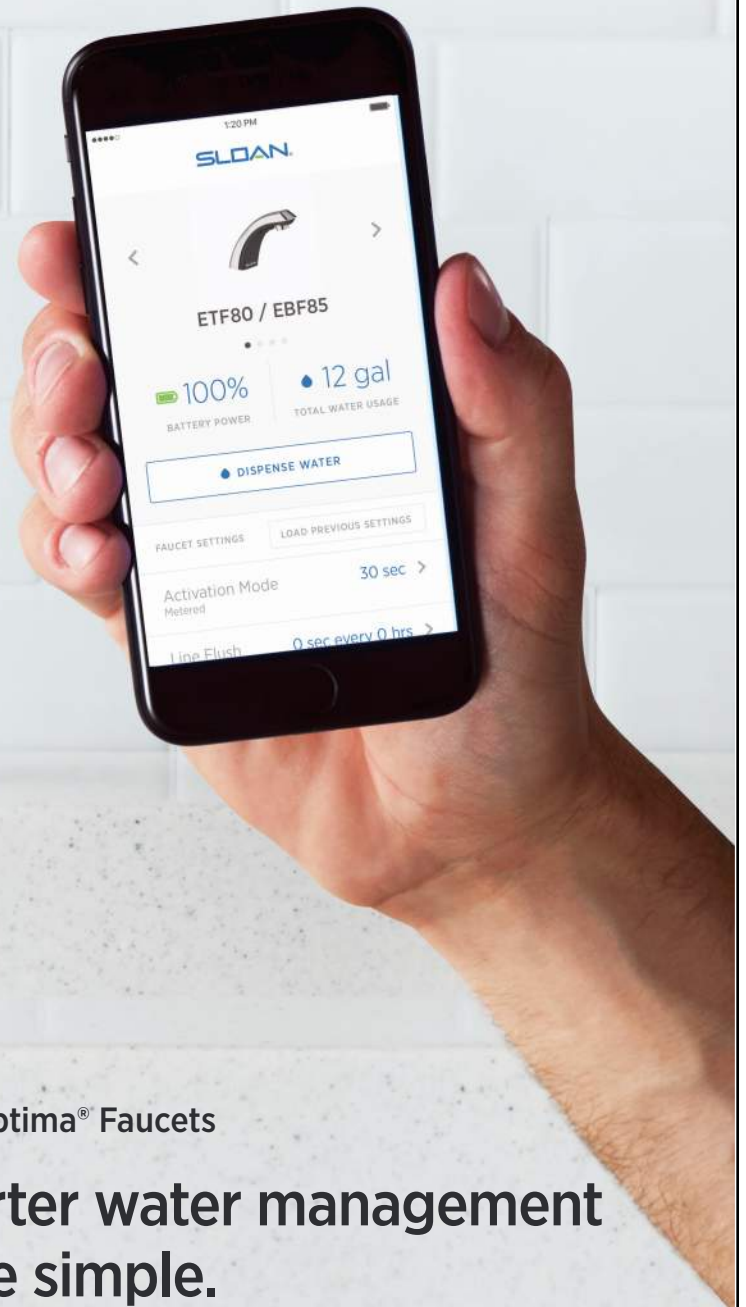

The new Optima® Control Box provides standardized components, multiple power options and quick-connect technology.

Sloan Optima® Faucets

Smarter water management made simple.

Meet the revamped Optima Faucets from Sloan. Quite possibly the most innovative water management system on the market, there are fewer parts and more standardized components, helping to reduce installation and maintenance by 50% or more. Paired with our intuitive Sloan Connect® App, you can manage faucets wirelessly without ever getting your hands dirty.

Call Sloan representatives Edwards, Platt & Deely at 631.253.0600.
Visit sloan.com/optima-faucets to learn more.



Download the Free Sloan Connect App for iOS and Android.

Specify with Confidence



Aqua Bath

Acrylic ADA/Barrier-Free and Institutional Bath & Showers Systems
www.aquabath.com



Advance Tabco

Commercial, Industrial and Institutional Stainless Steel Sinks & Faucets, Scrub Sinks & Faucets, Tables & Clean Room Equipment
www.advancetabco.com



Hydrotek International Inc.

Sensor Faucets, Non-Diaphragm Flush Valves & Showers (Eliminates Run-On with Superior Piston Design)
www.hydrotekintl.com



Kusel Equipment Co.

Stainless Steel Drainage Products
www.kuselequipment.com



Precision Hydronic Products

Heating Manifolds & Modular Hydronic Assemblies
www.phpinc.us



Precision Plumbing Products

Water Hammer Arrestors, Laundry & Ice Maker Utility Boxes, Trap Priming Systems, Pressure Balance Valves & Access Doors
www.pppinc.net

WOODS & JAYE

MANUFACTURERS' REPRESENTATIVE



SCAN FOR RIGHTSPEC® SIZING GUIDE



SCAN FOR JEV SUBMITTAL

MEET THE JEV LARGE VOLUME ELECTRIC POWER WATER HEATERS



BUILT FOR CHALLENGING ENVIRONMENTS

Spec Niles Large Volume Electric Power Water Heaters for Your Toughest Commercial Applications

- **EFFICIENT.** Meets the ASHRAE 90.1b standard for minimizing heat loss for big savings and operating efficiency.
- **ACCURATE.** Magnetic contactors with immersion thermostats. 120 volt control circuit with built-in transformer. Elements are thermostatically controlled in 54kW (max) increments for greater accuracy.
- **RELIABLE.** Copper-sheathed low watt density incoloy elements successfully resist the effects of prolonged high operating temperatures, hard water, acids, corrosion and thermal shock. Provides long life and reliable operation even under difficult conditions.
- **DURABLE.** Ultronium® glass is applied to the inside surface of the steel tank and fired to 1600°F for superior protection against corrosion. Magnesium anode protects against corrosion of the tank due to electrolysis.
- **TYPICAL SPEC.** Water heaters shall be Niles Steel Tank Electric Power Water Heater Series model number _____, with _____ gallons of storage capacity, rated at _____ kilowatts, _____ volts, _____ phase. Heater to be completely insulated and jacketed for vertical installation.

SHOP-BUILT PRESSURE VESSELS, STEEL TANKS AND MORE
nilesst.com | info@nilesst.com | 269.683.1910

REPRESENTED BY WOODS & JAYE SALES
Technical Questions: Support@wjny.com | 718-786-8260



©2021, Bradford White Corporation. All rights reserved. NSTPLEN1221

New York's Representative
of Jay R. Smith Mfg. Co.



HEAVY-DUTY TRENCH DRAIN SOLUTIONS

Designed with The Contractor In Mind.

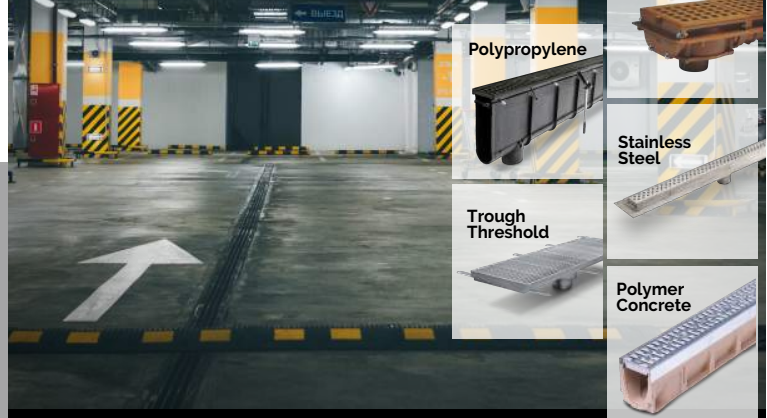

Cast Iron

Polypropylene

Stainless Steel

Trough Threshold

Polymer Concrete

From elegant shower drains to heavy-duty industrial drains, Woods and Jaye Sales, Co. can provide a full line of trench drain products to suit a wide variety of applications.



MANUFACTURERS' REPRESENTATIVE

www.wjny.com

Contact Us Before You Start
Your Next Trench Drain Project.

Phone: 718-786-8260

Email: support@wjny.com

ROOFTOP CROSSOVER STAIRS



- ✓ 20-year warranty
- ✓ Made in the U.S.A.
- ✓ Engineering available



Call **718-786-8260** for a quote.

Learn about all MIRO rooftop support products MIROIND.COM



WHY MPAV/PALL FILTRATION SYSTEMS?

Simple, Compact, Durable Low-Cost Design

The MPAV/Pall filter housing design is extremely compact with no internal moving parts and nothing to fail other than replacing the cover gasket seal every few years.

Adjustable Filter Rating

The Pall filter rating can be easily adjusted (either finer or coarser) by installing elements with a different micron removal rating after each routine disposable filter element change-out.

Predictable Filtration Performance

MPAV/Pall filter cartridges have a known single-pass micron particle size removal rating that does not change while in service because they use a depth style filter media that is effective at capturing particles in a single-pass no matter their shape, unlike mesh strainer filter designs.

Minimizes Bacteria Growth

When Pall elements are changed every few months the housing can be easily flushed out, cleaned, and disinfected to eliminate any sludge deposits where bacteria can grow.



APPLICATIONS.

- New construction or retrofit applications
- High flow and low flow applications
- Incoming city water and domestic hot water systems
- Filters sized to limit clean pressure drop to <2 psid



SCAN TO DOWNLOAD SPECIFICATION OR
CALL US TODAY FOR A FREE CONSULTATION
& SIZING P/N ENGINEERING SPECIFICATIONS



MANUFACTURERS' REPRESENTATIVE

SUPPORT@WJNY.COM | 718-786-8260
WWW.WJNY.COM



NJ/NY/PA
MANUFACTURERS' REPRESENTATIVE FOR
COMMERCIAL PLUMBING PRODUCTS



COMMERCIAL PLUMBING SOLUTIONS

- **A.O. Smith** - Gas Fired & Electric Water Heaters, DHW Heat Pumps
- **Diversified Heat Transfer (DHT)** - Indirect Water Heaters
- **Ebara** - Submersible Sump & Sewage Pump Systems, Elevator Sump Pumps
- **Griswold Controls** - DHW Re-circulation Systems NSF Automatic Flow Balancing Valves
- **Iorex** - Water Pipe Corrosion Protection
- **Keflex** - Expansion Compensators & Joints, Pump Connectors & Pipe Guides
- **QuantumFlo** - Water Pressure Boosters
- **Taco** - Leak Detection Controls, Re-circulation pumps, & Flow Thru Thermal Expansion Tanks
- **TracPipe** - Stainless Steel Flexible Gas Piping
- **Uponor** - PEX-A Plumbing Pipe Systems
- **Water Control Corp.** - Legionella/Pathogen Control & High-purity Water Systems, Water Reclamation & Filtration Systems

Please contact:
John Knowles
jknowles@walesdarby.com

walesdarby.com

Wales Darby - New York
2910 Express Drive South
Islandia, NY 11749
(631) 585-6800
infony@walesdarby.com

Wales Darby - New Jersey
5B Powder Horn Drive
Warren, NJ 07059
(732) 560-1001
infonj@walesdarby.com

Wales Darby - Pennsylvania
1650 Market Street #3600
Philadelphia, PA 19103
(267) 370-5204
infopa@walesdarby.com

WDS WASTEWATER DIVERSION SYSTEMS, INC.

MADE IN AMERICA

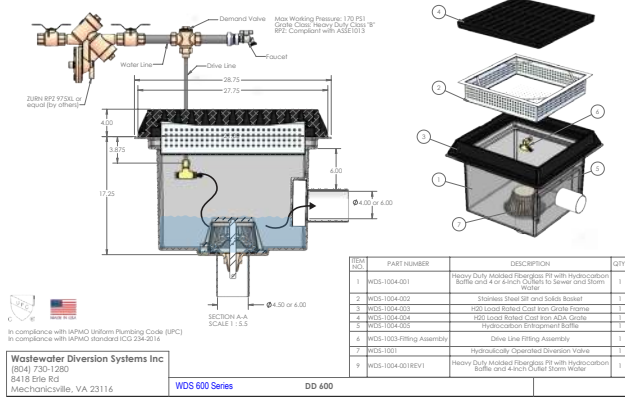

No. 1 in Appearance, Construction, Performance & Warranty

Advantages over Imported systems

- *American made Lead Free Brass Diversion Valve
- *American Made Lead Free Brass Demand Valve
- *Heavy Duty Molded Hand Laid Fiberglass pit
- *Chemical Resistant Fiberglass Resins and Gelcoats
- *Baffled Stormwater Outlet for First Flush Protection
- *Optional SS pits for Custom Sites
- *Stainless Steel Silt & Solids Baskets
- *H2O Cast Iron ADA Grate & Frame
- *2" 4" or 6" Outlets to Sewer & Storm Water
- *1" NPT in & out Demand Valve Thread
- *No Electric or Roof needed
- *Concrete pits unnecessary
- *Provides Treatment for all Washdown Areas
- *IAPMO UPC IGC234-2016 & CITIES APPROVED
- *Meets CA Prop 65 Requirements

Applications

- *Car Wash & Detail Sites
- *Beach, Deck & Pool Showers
- *First Responder Chemical Showers
- *Trash Bin Drainage Areas @ Schools & Fast-Food Sites
- *Roof Top Dog Parks and Kennels
- *Auto Part Recyclers
- *Marinas & Boat Wash Down
- *Loading Docks
- *Aircraft Washdown

How it Works

The Hydraulic Actuated Diversion Valves by Wastewater Diversion Systems will automatically send all wash water to the sewer and clean rainwater to the storm drain.

When the demand valve detects water use on the wash pad it sends water down the drive line to hydraulically actuate the pit mounted diversion valve sending all wash water entering the pit to the sewer.

When washing is finished and detected by the demand valve, drive line water also ceases allowing the diversion valve to close.

Valve is closed; sewer is sealed and protected from rainwater. The baffled stormwater outlet performing as an oil water separator will keep free floating pollutants from a First Flush of rain inside the pit to be sent to the sewer at beginning of next wash down operation.

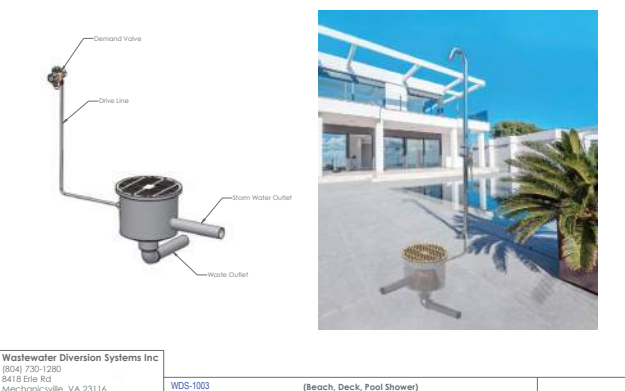
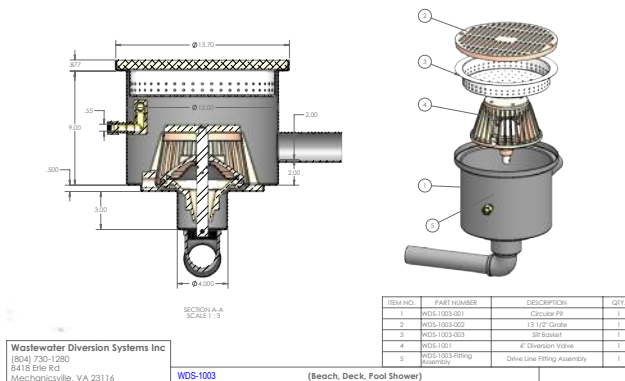

IAPMO R&T Tested & Complies with IGC234-2016

THE BEST DIVERSION SYSTEMS WORLDWIDE

P: 804-730-1280
E: foxwwdsusa@aol.com
W: eeeusa.net

SLOAN



Sloan DropSpot™ Bottle Fillers

TEMPER WATER. NOT EXPECTATIONS.

CONSISTENT TEMPS
IN HIGH AND LOW DEMAND

WORKS WITH NEXA
FOR MORE INSIGHT & CONTROL

PRE-PIPED OPTIONS
FOR YOUR UNIQUE NEEDS



works with nexa



IntelliStation | 2

Unmatched Versatility. Effortless Efficiency.
Experience the Next Generation of Digital Mixing.



Scan to
Learn More

POWERS™
A WATTS Brand

PowersControls.com

Learn How • Read Engineering Papers

McGuire's new integral check valve defends against backflow and cross-connection contamination. Read the whitepaper and engineering reports authored by Julius Ballanco, P.E.

Scan the QR code or go to mcguiremfg.com.



ICV DEFENDER

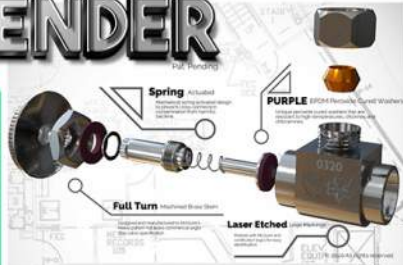

Pleased to be represented by:



Go To Reports

mcguiremfg.com



WARNING: This product can expose you to chemicals including lead, which is known to the State of California to cause cancer, and lead which is also known to cause reproductive harm. For more information go to www.P65Warnings.ca.gov



368 Wyandanch Ave
North Babylon, NY 11704
Phone: 631-253-0600
<http://www.epdreps.com>



THE BOLD LOOK
OF **KOHLER**®



Tend® Integrated Touchless Urinal

Designed to deliver a **more cost effective solution**. Touchless urinals with integrated flush valve provides the cleaner lines and look of a rear spud urinal with the easy valve access of a top spud. Available in 0.125 and 0.5 gpf options.

Flexible Install & Maintenance

- Designed for high traffic restrooms, yet fully functional for man caves and other residential spaces too
- Fewer overall plumbing connections
- Includes supply connection, making install easy for both commercial and residential applications.
- Tank cover and cover locks provide vandal protection.

Clean Space, Clean You

- Touchless valve utilizes an integrated sensor to drive a dependable flush.
- Washout design fully rinses the urinal with each flush for a cleaner fixture.
- Patented backwall geometry and extended rim, limit splash-back for a cleaner restroom and user experience.
- Includes stainless steel low-profile strainer for faster drain flow.
- Smooth contours make cleaning fixture fast and easy.



YOUR FULL SERVICE MANUFACTURER & DISTRIBUTOR

IN THE GREATER NEW YORK AREA



FABRICATION EXPERTS

CUSTOM FABRICATION FOR QUICK, RELIABLE PUMP REPLACEMENTS.



ALWAYS STOCKED

OVER \$15 MILLION IN-STOCK ACROSS FOUR LOCATIONS, ENSURING ACCESS TO THE PARTS YOU NEED



RETROFIT-READY

TECHNICAL DRAWINGS DESIGNED TO SIMPLIFY YOUR SYSTEM UPGRADES.

EMMONSPUMP.COM • (518) 694-0404

	(815) 886-9200 Romeoville, IL 60446	METROPOLITANIND.COM		(518) 694-0404 Albany, NY 12204	EMMONSPUMP.COM
--	---	---------------------	--	---	----------------

WE HELP PLUMBING ENGINEERS

PLAN BETTER BUILDINGS

SO CONTRACTORS CAN BUILD BETTER RESTROOMS THAT SAVE SPACE AND RESOURCES

Geberit in-wall installation systems offer operational efficiency, installation flexibility, improved aesthetics, accessibility, space, and water savings. Geberit carriers are available for toilets, lavatories, and bidets.

A PARTNER TO RELY ON Geberit Offers Professional Support

- Advice on Product Selection
- Planning Support
- Project Monitoring
- Site Visits
- BIM Data

Meet with Sarah DeMartino before you start your next project and learn how to simplify the building process with Geberit.

Email: Sarah.Demartino@geberit.com
Mobile: 1-646-265-3592

www.geberit.us



LAARS E-THERM™

CO2 Air Source Heat Pump Water Heater

- No HX or Glycol Necessary
- 325,000 BTU
- Up to 180F sanitizing water
- Made in the USA



CONTACT US TO LEARN MORE AND GET MORE INFORMATION ON WHY THE E-THERM IS THE RIGHT HPWH FOR YOUR NEXT JOB



631-822-1200



ratheassociates.com



1650 New Highway
Farmingdale, NY 11735

dellon

Dellon Sales Company

QUESTIONS?
help@dellonsales.com

5 ALBERTSON AVE,
ALBERTSON, NY 11507

TO ORDER:
orders@dellonsales.com

P: 516-625-2626
F: 866-811-6436

DELLONSALES.COM

NEW YORK & NEW JERSEY LINE CARD

FIXTURES



Duravit
High end fixtures, bathroom furniture & accessories.



Elkay, Halsey Taylor
Stainless steel, fireclay & quartz sinks, electric water coolers, bottle filling stations and faucets.



In-Sink-Erator
Food waste disposals, instant hots.



Just Mfg
Full line of commercial drop-in, undermount, and institutional stainless-steel sinks and accessories.



Mr. Steam
Steam bath generators, wireless controls, linear steam heads, towel warmers.



Niagara
Ultra-high efficiency toilets with hydraulic technology.



Fiat
Terrazzo & molded stone bases, mop receptors, laundry tubs, faucets.



Bemis
Toilet seats and bidet seats.



Bootz
Porcelain enameled bathtubs and shower bases & bath/shower walls.



Fluidmaster
Fill valves, connectors, tank levers and flappers.



Pfister
Premier bathroom and kitchen faucets, shower heads, and accessories.



Stingray
Emergency showers, eyewash, face wash and accessories.



QuickDrain
Shower floor solutions, linear shower drains.



Zurn Fixtures
Commercial faucets, flush valves, sensor products, commercial fixtures, & ZurnOne fixture packages, shower valves.



HEATING

Argo Baseboard
Finned-Tube baseboard radiators.



Embassy Industries
Traditional baseboard radiation, hydronic kickspace heaters, low temp/ high efficiency baseboard radiation.



Rheem
Commercial and residential water heaters, heat pumps, tankless heaters and more.



Ruud
Tankless, gas, and electric water heaters, heat pumps and other HVAC systems.



IBC
Gas fired wall hung boilers and combis.



Raypak
Commercial boilers, large capacity water heaters, and storage tanks.



Cross Manifold
Motorized, self-contained boiler manifold for radiant and hydronic heat.



Eemax
Tankless water heaters for residential, commercial and industrial applications.



Ultra-Fin
Aluminum fins that attached to pex tubing under the floor joist! Easy radiation.

PIPE VALVES & FITTINGS



Tyler Pipe Co
Domestic cast iron soil pipe.



Greenfield
Pipe hangers and plumbing specialties.



IPEX
PVC/CPVC/ABS pipe & fittings, acid waste systems; Blazemaster pipe & fittings.



Mueller Industries
Copper press and sweat fittings and tubing, PVC, specialties.



Stockham
Quality bronze cast iron, cast steel, ball, butterfly, gate & check valves.



Therm-Omega-Tech
Circuit Solver self-adjusting thermostatic balancing valve, drain tempering valves.

PLUMBING



Anaco/Tyler
Couplings Domestic no hub couplings, specialty, transition couplings.



Dab Pumps
Pumps and water pressure boosters.



Floodmaster
Plumbing leak detection & automatic shut-off solutions.



Harris
Sterling solder, brazing rods, torch kits.



Husky Couplings
Heavy-duty no hub couplings.



H2O Degree
Sub-metering systems for tenant billing, and building automation.



Halo
Water filtration systems.



HotBox
Heated and non-heated enclosures for backflows and rooftop equipment.



Lawler
Smart digital control & remote monitoring thermostatic mixing valves, high-lo and pou valves.



Saniflo
Above the floor pump systems. Macerating & grinding pumps, acid neutralization, condensate removal.



Wade Drains
Drains, carriers, hydrants, interceptors.



Oatey/Hercules
Laundry & ice boxes, water hammer arrestors, pipe hangers, supports, tub protectors, AAV's, stops valves, plumbing and heating chemicals.



Zurn Drainage & Wilkins
Trench drains, cleanouts, carriers, interceptors, hydrants, floor sinks, backflow preventors, automatic control valves, pressure regulators.

TOOLS



Milwaukee
Heavy-duty power tools, hand tools, instruments, and accessories.

WELCOME TO THE APSE NYC EDUCATION CENTER

FROM THE EDUCATION CHAIR



Pump Basics

A pump's job is to move fluids by adding energy, typically by increasing pressure or flow, to transfer them from one location to another, lift them to a higher level, or move them from low to high pressure areas. This allows us to wash our hands, flush out toilets, heat our spaces and help during a fire emergency. All pumps have two main components in common, which are the motor and the impeller.

The Motor is the main driving force of the system. It provides the necessary power via rotational energy to generate the required flow and pressure in the pump system. Typically, the motors are electric but can also be diesel, gasoline or natural gas powered depending on the application and availability of a power source.

The Impeller transfers the motor's rotational energy to a fluid, acting as the heart of a centrifugal pump by accelerating the liquid outward, increasing its velocity, and converting that kinetic energy into pressure to move it through the system. The 4 most common pump applications in plumbing systems are:

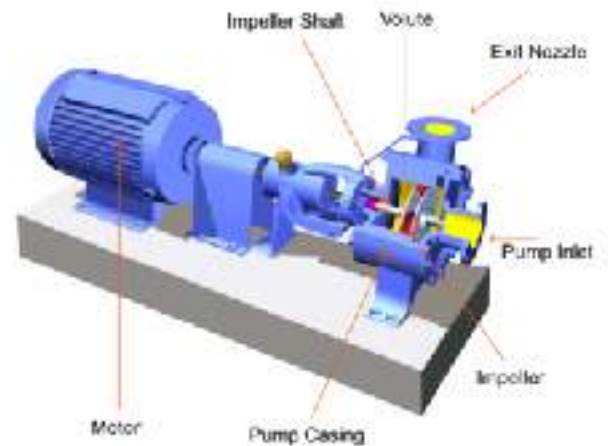

Pressure boosters for domestic water systems which ensure adequate flow to all fixtures, especially in multi-story buildings where the municipal supply may not be sufficient.

Sprinkler and standpipe systems which provide the necessary water demand to sprinkler and standpipe systems during fire emergencies.

Water circulation pumps for heated water systems provide the movement of hot water throughout a building's plumbing system, ensuring that hot water is readily available at fixtures without long waits.

Sanitary and Sump pumps which are used in plumbing systems to move water— typically from fixtures located below the main sewer line, like in a basement or cellar—up to a level here gravity can carry it away.

More information on the different pumps systems can be found in the APSE Plumbing Engineering Design Handbook Volume 4, Chapter 4. The ASPE Design handbooks serve as a great reference tool for both new engineers who are learning about plumbing design as well as seasoned engineers who want to hone their knowledge.

viega

VIEGA FITTINGS AND VALVES
ARE TESTED TO THE
HIGHEST
STANDARD

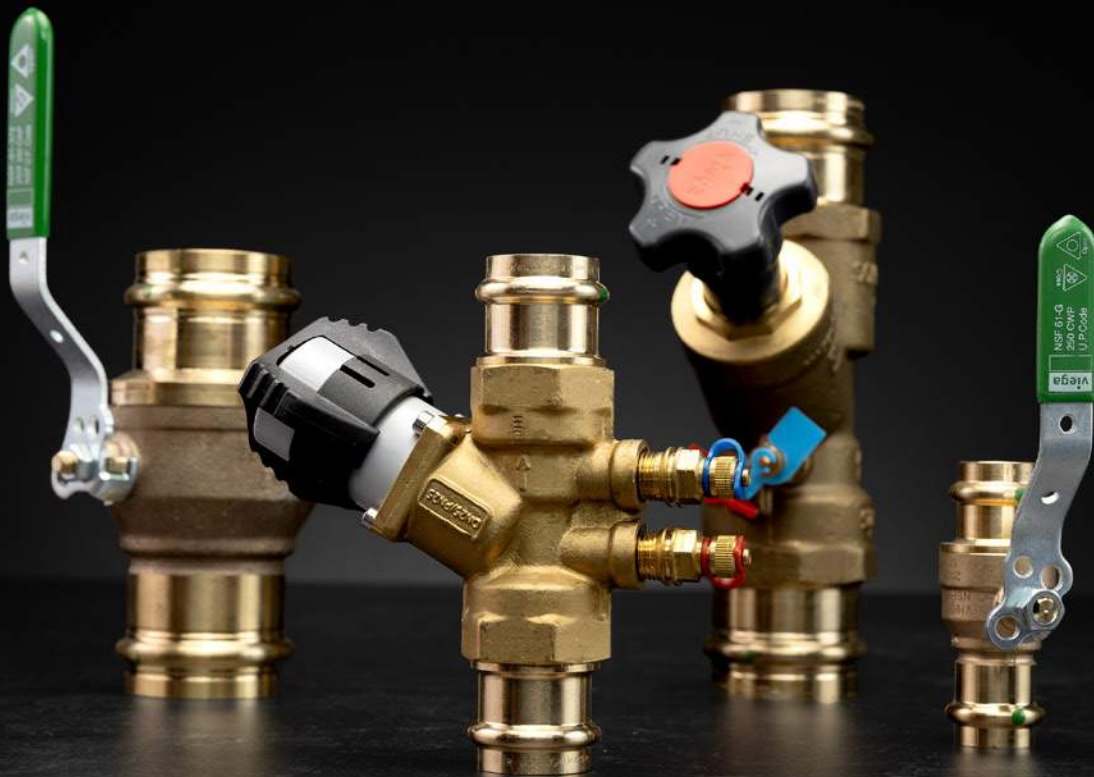

— BOOK YOUR VISIT
TO THE NY VIEGA EXPERIENCE CENTER.



SCAN TO SCHEDULE NOW!



YOUR ONE SOURCE FOR ALL
YOUR PLUMBING & HEATING NEEDS



AXIOM



DuraVent



turbomax



CALL TODAY 631-822-1200 OR VISIT WWW.RATHEASSOCIATES.COM

Four generations of experience and knowledge servicing
the New York City real estate community.



If water runs through it, we do it.

AMERICAN PIPE & TANK LINING CO., INC.

MANHATTAN COOLING TOWERS INC.

AMERICAN CONTRACTING CO., INC.

NEW YORK WOOD TANK CO., INC.

Wood & Steel Tanks • Plumbing • Cooling Towers

24/7/365

11-42 46th Rd., Long Island City, NY 11101
(212) 736-6618 • F: (212) 465-1734

contact@americanpipeandtank.com
www.americanpipeandtank.com



A ThermOmegaTech® brand

The Best In Balancing

Now Backed By An Unmatched 10-Year Guarantee.

CircuitSolver thermostatic balancing valves automatically balance hot water recirculation systems. They ensure hot water availability and now come with an industry-leading **10-year warranty.**



Contact For More Info
(516) 625-2626
www.dellonsales.com

dellon
Dellon Sales Company



Commercial Water

Kevin Brace
Senior Specification Specialist
Kevin.Brace@Rheem.com



Providing Hot Water Solutions from the Rheem Family Products



Eemax[™]
evolving hot water

Raypak[®]
A Rheem[®] Company



For more information
Visit: Rheem.com/commercialwater
For Submittals, Revit Files, and Sizing Programs for All Brands

ASPE NYC PAST PRESIDENTS

Richard Reilly	1976 - 1977	James Walsh	1997 - 1999
Frank Scalia	1977 - 1978	Rick Sorvillo, FASPE	1999 - 2001
Bert Geller	1978 - 1979	Rick Stamm	2001 - 2003
Pat Tighe	1979 - 1980	Vincent Quatraro	2003 - 2005
Richard Toder	1980 - 1981	Anthony Merlini	2005 - 2007
Vincent Pantuso	1981 - 1983	Hershel Weiss	2007 - 2009
Steve Winter	1983 - 1985	Leon Perkolaj	2009 - 2011
Jose R.Baz	1985 - 1987	Philip Parisi	2011 - 2013
Al Collado	1987 - 1989	Vincenzo Rotoli	2013 - 2015
Fred Barber	1989 - 1990	Salvatore Rachiele	2015 - 2017
Frank St. George	1990 - 1992	Jared Donnhammer	2017 - 2019
Ed Wallace	1992 - 1995	Joseph Tagliaferro	2019 - 2021
Tim Allinson	1995 - 1997	Robb Risani	2021 - 2025

| THE NEW YORK CITY CHAPTER OF ASPE WAS CHARTERED ON 10/27/75 |

MILLIONS OF PEOPLE DEPEND ON



HARPER CONTROL SOLUTIONS, INC.

We are the Solution!

Call Harper Control Solutions – We are the Solution!

203-964-1900 | HarperValves.com | 855-364-4100 | 1010 Washington Blvd., Stamford CT 06901

Cla-Val Products
 Cla- Val Service
 JRG - Hot Water Balancing Valves

Vent-Tech – Air Valves
 Control Panels
 Ejector Pit Control Panels
 Level Control Panels

Pump Control Panels
 Shelco – Filtration Products
 Toshiba – Magmeter

INDUSTRY LEADING COLD CLIMATE PERFORMANCE

149F OUTLET WATER
-4F OPERATION



100% GUARANTEED SYSTEM PERFORMANCE

EST. 1924

Take advantage of our performance guarantee
ASK US!

100 Years supporting engineers and contractors with energy efficient heating, cooling, and DHW solutions.

ASK ABOUT OUR PERFORMANCE WARRANTY



DESIGN ASSIST



PRODUCT SIZING AND SELECTION



PRODUCT SOURCING



FIELD SUPPORT



EXTENDED WARRANTY

Heat Pumps | Boilers | Water Heaters | Drives
and everything in between



SCAN ME

Wallace Eannace | 800.932.4454 | wea-inc.com



Lochinvar



Bell & Gossett



CEMLINE CORPORATION



GOULDS WATER TECHNOLOGY
a xylem brand



Metraflex
for pipes in motion

Countless Solutions All Built to be the Best®



Residential and commercial solutions offering exceptional performance, efficiency, reliability and innovations, including Microban® antimicrobial technology inside all tank-type water heaters.

Learn more



Microban® antimicrobial product protection helps prevent the growth of bacteria, mold and mildew that may affect the product. The built-in antimicrobial properties do not protect users or others from disease-causing organisms. Microban® is a registered trademark of Microban Products Company. ©2025, Bradford White Corporation. All rights reserved.

ASPE NEW YORK CITY CHAPTER SPONSOR RATES

AD SIZE	PRICE
Qtr. Page	\$660
Half Page	\$1325
Full Page	\$2475
8.5" X 11" Insert	\$675 (Monthly)

NEW SPONSORS ARE PRORATED!

Email Robb Risani: nycaspenewsletter@gmail.com

Take the guesswork out of life safety.



- ✓ **Earn continuing education credits**
Stay current with courses that enhance your knowledge and certifications.
- ✓ **Specification review & assistance**
Need help with complex specs? Our experts are ready to guide you.
- ✓ **Project-specific detail review**
We provide personalized support tailored to your project's needs.

access.stifirestop.com





is a proud supporter of

American Society of Plumbing Engineers NEW YORK CITY CHAPTER



PLUMBING TECHNOLOGIES

- Domestic water booster packages
- Direct inline pump systems
- Expansion tanks and air separators
- Gasketed and brazed heat exchangers
- Heat pump water heaters
- Rainwater harvesting
- Self cleaning screen filters
- Submersible sewage pumps
- Tanks, valves and other specialties
- Wastewater energy recovery

FEATURED PARTNERS



Scan to view our full lineup of technologies and partners or visit highmark.co/technologies



ABOUT HIGHMARK

Pioneering efficient building technologies since 2013. HIGHMARK represents manufacturers across the globe, providing the best building-efficiency technologies to support sustainability, electrification and decarbonization.

CONTACT

49 West 45th Street, 6th Floor
New York, NY 10036
212-920-4878
highmark.co
info@highmark.co



[linkedin.com/company/highmark-be](https://www.linkedin.com/company/highmark-be)



[@highmark_be](https://www.instagram.com/highmark_be)



Our Tradition of Excellence Continues

YESTERDAY, TODAY—AND ALWAYS



Generations of loyal customers have relied on Holby Valve for superior products that are made to last.

For 90 years, our high-performance tempering valve has been the gold standard in our industry.

Now, our latest product—the HolbyMonitor—continues this tradition of trust and value.

This tech-savvy temperature tracking device delivers invaluable water temperature information so that you can act quickly and decisively when problems arise. You'll have the data in an instant, wherever you are.

Thanks to our commitment to quality, dependability and customer satisfaction, you can rely on the Holby Valve and HolbyMonitor to meet your tempered water needs.

973.465.7400
sales@holby.com
holby.com



TRUSTED PUMP MANUFACTURER
REPRESENTATIVE FOR
OVER 60 YEARS!



"THE PUMP BOYS"

CULLEN

732-988-9600 | CULLENCOMPANY.COM



KIMAX® drainline systems for chemical waste applications

Built to last. Proven in the field. Corrosion-resistant, long service life, code compliant, easy assembly.

Contact your local distributor:
JG, Inc.
11 Lamson Ave. Suite 101
Pawtucket, RI 02861
(401) 427-4900
kjg@jginc.com

SCHOTT

A Water Heater for Any Project

Commercial water heaters in all sizes, gas, electric, steam, and more



Chris Memmelaar
682.220.3348
cmemmelaar@pvi.com

Reshad Farauk
914.462.0495
reshad.farauk@wattswater.com





MEMBERSHIP INFORMATION

Time to renew your membership, our records indicate your membership is due to expire on 2/28/26:

Paul Ahn
Adia Bodden
Mitchell Castell
Joseph Colello
Bryan Dicciardello
Alfatih Elsheikh
Michael Ford
Anthony Gamba
Gregory Giuliani

Kamrul Hasan
Jason Lee
Ivana Ljoljic
William Lobdell
Jonathan Mann
Jennifer McCann
Chris Memmelaar
Alpesh Mistry
John Mullen

Leo Pollack
Keith Powers
John Rocchio
Richard Ryan
Dominic Tagliafierro
Adrian Toma
Kyle Walton
John Woytalewicz

FEBRUARY BIRTHDAYS! BEST WISHES FROM NYC ASPE

James Alimo
Nicholas Arrowsmith
Jake Cerasoli
Thomas Clifford
Andrew Davies
Christina Deeks
Steven Deland
Brendan Dowd
Ed Garcia

Grace Geckeler
Christian Goodhue
Lou Graravito
John Grosso
Jacob Lawrence III
William Lobdell
Abdul Rehman M
Robert Marsiglia
Des Murphy

Derek Paniccia
Nick Pannunzio
Steven Pelletier
Jared Pennings
Leon Perkolaj
Salvatore Rachiele
Ahmed Soliman

**For membership questions please contact
Steve Ryback at steve.ryback@wjny.com**



159 Express Street,
Plainview, NY 11803
Tel: 516-349-5959
Fax: 516-349-0709
Email: info@quimbyinc.com

Serving the Industry Since 1947

Representing

A-C FIRE PUMPS

Fire Protection Pumps ▪ Electric ▪ Diesel
Turbine ▪ Sprinkler ▪ Standpipe ▪ Residential

GRUNDFOS PUMPS

Pressure Boosting Pumps
Wastewater Pump Systems

GOULDS PUMPS

Pressure Boosting System ▪ Wastewater
Multi-Stage Pumps ▪ Oil Smart Pumps

CRANE PUMPS

Barnes ▪ Weinman ▪ Deming
Sewage ▪ Grinder/Slicer ▪ Sump

PRIMEFLOW BOOSTER SYSTEMS

Wide Range of Pressure Boosting Systems
Premium Efficient ▪ VFD & PRV Types

SICO SYSTEMS & CONTROL

Pressure Boosting Systems
VFD, PRV, Tank-Fill & Fuel



ISSEKS BROS.

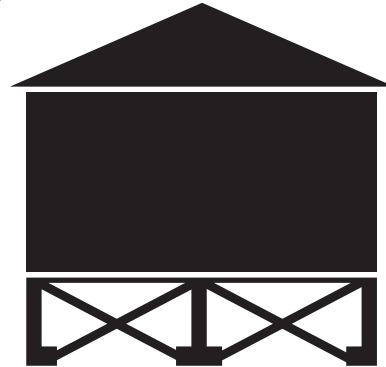

TANKS Est. 1890

(212) 267-2688

www.isseks.com



pH & Lift Station Systems

Turn-Key & Ready to Use pH Systems:

Pre-engineered for quick installation and operation.

Durable Design:

Built with NEMA 4X enclosures and corrosion-resistant materials.

Compact & Efficient:

Space-saving design with reliable pH control for any operation.

Proven & Guaranteed:

40+ years of success with a 1-year component replacement warranty.

Safe & Flexible:

Custom alarms, chemical containment, and advanced control options.



Pump Lift Station Systems:

Ready-to-ship solutions for areas without gravity drainage.

Simplex (single pump) and Duplex (dual pump) options.

Corrosion-resistant, temperature-tolerant, with automatic On/Off.

Custom Solutions:

Tailored for your needs.

Flow rates: 1-1,000+ GPM, tanks: 5-15,000 gallons.

Advanced controls, leak detection, and multiple pump types.



Contact Us:



www.burtsystems.com



203-287-1985

NYC LICENSED
MASTER PLUMBER
VINCENT GAMBA
#1580



OLYMPIC

Plumbing & Heating

4 AERIAL WAY, SYOSSET, NY, 11791
718-528-4001
EMAIL: INFO@OLYMPIC-PLUMBING.COM

**SPECIALIZING IN HIGH-QUALITY AND CUSTOMIZABLE AIR,
VACUUM, AND PIPELINE PRODUCTS FOR MEDICAL
AND LABORATORY APPLICATIONS**



Jonathan Mann | ASSE 6010,6030,6035
Medical and Laboratory Gas Consultant
332-270-9074 | jonathan.mann@pattonsmedical.com
www.pattonsmedical.com



**CONNECT WITH A MEDICAL AND
LAB GAS CONSULTANT TODAY**

DOLPHIN EQUIPMENT CORPORATION

Serving all your hydronic plumbing needs and solutions in the NJ and NY area for nearly 30 years.

Domestic Water Boosters, Tank Fill, Domestic Hot Water Heating & Custom Pibg. Systems, Mixing Valve Stations, Domestic Hot Water Heat Exchangers, Hydropneumatic Tanks, Sump/Sewage Systems, Elevator Oil Sensing Pumps, Direct Inline Sump/Sewage Systems, Valves and Hoses, Water Heater & Hydronic Boiler Modular Systems, Fire Pump Systems



NIBCO[®]
presssystem[®]

FIND YOUR FIT

Choose from Over
500 Press Valve SKUs,
the Largest Offering
in the Industry

FIND YOUR FIT AT
NIBCO.COM/PRESS

Geoffrey Steneck | Area Sales Manager
732.768.3229 | steneckg@nibco.com

Greg Amicucci | Commercial Sales Manager
631.304.4955 | amicuccig@nibco.com

The PrePaK™ Cabinet

Now with  **VAPOR**
Pipe Shield

Corrosion Prevention for Dry & Preaction Systems



The PrePaK™ Cabinet

Quiet operation, compact design
ideal for occupied spaces

Powder-coated steel construction

Factory-wired terminal box
consolidates connections

Easy service access

Vapor Pipe Shield® for corrosion protection

New streamlined Model DD
Air Maintenance Device

Time-tested Model DDX valve
with external reset for easy
service



Now available in the trusted PrePaK™, Vapor Pipe Shield® uses advanced VpCI® technology to prevent internal pipe corrosion with a low-maintenance design engineered for efficient system protection.

For technical questions or information, contact tech@reliablesprinkler.com or call 1-800-557-2726.

Vapor Pipe Shield® is a trademark of General Air Products, Inc.
VpCI® technology is a trademark Cortec Corporation



Reliable®

JANUARY MEETING MINUTES

The January meeting was initiated by Steve and began with the Pledge of Allegiance, after which, a couple announcements were made. There is an ASSE 6060 Medical Gas Workshop March 23rd-26th. Link to register can be found on the website and in this newsletter. The ASPE/ASSE summer golf outing will be on Monday, August 10th.

Technical Presentation: Code Requirements for Rooftop Equipment and Supports by Luis Capunay

Luis outlined the objectives of the presentation, which included identifying common failures associated with rooftop supports, reviewing applicable building and trade codes, examining real-world damage examples and FEMA assessments, clarifying responsibility for design and installation, addressing delegated design and deferred submittal requirements, and reviewing examples of compliant rooftop support systems.

The presentation began by explaining why codes and standards exist for rooftop equipment supports. Referencing the **2024 International Building Code Section 101.3**, Luis stated that the fundamental purpose of building codes is to establish minimum requirements that protect life safety, public health, building integrity, and emergency responder safety. Rooftop equipment supports directly affect structural performance, waterproofing integrity, and occupant safety, making them subject to rigorous regulation. He noted that contractor “field-fabricated” supports frequently fail to meet these minimum requirements and are often rejected by building officials.

To reinforce the importance of compliance, Luis presented findings from **FEMA 489: Mitigation Assessment Team Report**, describing a documented wind failure involving a 30-foot by 10-foot by 8-foot HVAC unit weighing approximately 18,000 pounds. The unit was attached to a curb that did not meet code requirements. Despite wind speeds of only 85 to 95 miles per hour, the unit failed on a building that was less than 1 year old and located 20 feet from the roof edge. This example demonstrated that rooftop support failures occur well below extreme wind conditions when systems are improperly designed or installed.

Luis then reviewed the evolution of building codes and load standards applicable to rooftop supports, including multiple editions of the International Building Code and ASCE 7. He explained that current designs rely on the **2024 IBC** and **ASCE 7-22**, while older buildings may reference earlier editions such as ASCE 7-10 or ASCE 7-16. Regardless of edition, rooftop supports must be designed to meet required loads and conform to industry standards including IIAR, ASHRAE, MSS SP-58, SMACNA, NFPA 70, and roofing manufacturer requirements. Codes and standards must be applied together on every project to achieve compliance.

Luis addressed the question of why wind loading is always required while seismic loading is sometimes exempt. He explained that the **International Mechanical Code Section 301.15** mandates wind resistance for all rooftop mechanical equipment and supports without exception. FEMA assessments have shown that wind turbulence, uplift, and membrane damage occur regardless of perceived shielding from adjacent structures, and codes explicitly prohibit reducing wind loads due to shielding effects. Seismic loads, by contrast, may be exempt depending on geographic location and seismic risk category.

The presentation then examined what the codes specifically require. Luis explained that designers should begin with the trade codes—IMC, IPC, IFGC, and NEC—and conclude with the IBC and ASCE 7 for structural loading. The IMC requires that mechanical equipment and supports resist wind loads determined by the IBC and seismic forces where applicable. The IPC mandates structural attachment of plumbing piping supports and includes spacing tables, while the IFGC establishes similar requirements for fuel gas piping. NFPA 70 governs electrical conduit support spacing and attachment. Collectively, these codes require that rooftop systems be attached to the building structure in an approved manner and supported at prescribed intervals.

Luis emphasized that support spacing and attachment requirements exist to prevent system failures. He cited SMACNA provisions for duct support spacing, noting that wide ducts require closer spacing to prevent sagging. He also reviewed NEC requirements limiting conduit support spacing to 10 feet for metal conduit. These requirements exist because rooftop installations are exposed to wind, thermal movement, and vibration that can quickly cause failure if not properly supported.

Thermal expansion and contraction were identified as another critical design consideration. **IMC Section 1206.9**, **IPC Section 308.8**, **IFGC provisions**, and **NFPA 70** all require systems to accommodate expansion and contraction caused by temperature changes. Luis explained that failure to account for movement has led to cracked piping, damaged supports, and compromised roof membranes. Flexible connections and expansion fittings are required to prevent stress buildup.

Safety access requirements were also reviewed. **IMC Section 306.5** requires permanent access to rooftop equipment when access height exceeds 16 feet. Portable ladders are not permitted, parapet climbing is restricted, and walking surfaces must comply with **OSHA 1910 Subpart D**. Luis explained that safe access is a code requirement because rooftop systems require ongoing inspection and maintenance, and lack of access increases both injury risk and deferred maintenance.

Material selection was identified as a frequent source of noncompliance. IMC and IPC require approved materials that prevent galvanic action and can withstand static and dynamic loads. IFGC requires piping supports to meet strength and quality requirements. Luis challenged attendees to consider the long-term durability of supports and whether warranties exist to cover roof or equipment damage caused by support failure.

Luis then addressed structural loading requirements in detail. **IBC Chapter 16 and ASCE 7** establish minimum loads that must be considered, including dead load, live load, snow load, wind load, seismic load, and tornado load. He emphasized that wind loads can never be exempted or reduced, while seismic loads may be exempt depending on location. Snow drift and accumulation must be evaluated, and **ASCE 7-22** introduces tornado loading requirements for certain Risk Category III and IV buildings in tornado-prone regions.

Wind loading was highlighted as the most critical factor. ASCE 7 explicitly prohibits reductions due to shielding, and rooftop supports must be designed for lateral and uplift forces. Self-weighted or ballasted supports alone are not permitted because they do not provide positive attachment. Luis explained that many rooftop supports fail because they are not engineered and rely solely on weight rather than structural anchorage.

Responsibility for rooftop support compliance was clearly defined. Mechanical, electrical, and plumbing engineers are responsible for specifying support requirements for their respective systems. The Structural Engineer of Record provides structural design criteria and oversees delegated designs. The Architect of Record coordinates delegated design requirements. Contractors and roofers must provide deferred submittals prepared by licensed engineers. Specifications and drawings are the only means by which contractors understand code requirements, making proper documentation essential.

Luis reviewed deferred submittal requirements under **IBC Section 107.3.4**. At a minimum, rooftop support submittals must include engineering calculations demonstrating compliance with loading requirements, detailed shop drawings showing materials and connections, roof layout drawings indicating support locations, and a compiled engineering package stamped by a licensed professional in the jurisdiction.

The presentation concluded with code-compliant examples of engineered rooftop support systems that properly address wind, seismic, expansion, and attachment requirements while remaining non-invasive and compatible with roofing warranties. Luis emphasized that floating or sleeper supports alone do not satisfy code requirements.

In closing, Luis reiterated that engineered rooftop equipment supports are explicitly addressed in building codes to limit risk to life, property, and building operations. Standards exist to help each discipline meet code requirements, but responsibility ultimately lies with project professionals to ensure rooftop supports are shown, specified, and designed correctly on every project. The session concluded with a question-and-answer period and discussion of practical applications.





COMMERCIAL



EXPERIENCE THE PERFECT STYLE WITH ADVANCED FUNCTIONALITY

Architectural™ Design Series

Cutting-edge plumbing products that do not compromise on quality or durability. Featuring hands-free technology that incorporates beautiful aesthetics for high-use areas such as hospitality, transportation hubs, retail, and offices.

Customize your space with three design options and four exquisite finishes available in the Architectural™ Design Series.



Driftex™ Collection
Electronic Faucet/Soap Combo
810DPA20-BLSD



Contrasta™ Collection
Electronic Faucet/Soap Combo
820DPA20-SSSD



Rustica™ Collection
Electronic Faucet/Soap Combo
830DPA20-CZSD



Concealed Electronic Water Closet Flush Valve
1800D60TR

© 2025 Masco Canada Limited. All Rights Reserved.

DeltaFaucet.com/Commercial

COMMERCIAL PLUMBING SOLUTIONS



Women of ASPE®

Learn more about our group!



Email rrodriguez@aspe.org and visit aspe.org

Exclusive WOA Sponsor





Together over **100 years** of unparalleled experience and expertise

Your Experts In Natural Gas, Boiler & Domestic Hot Water Heating Systems

Specifying Brands Depended On For Decades...



Based in Queens since the 1940's!
79-05 Cooper Ave Glendale NY 11385
Need a selection? Call (718) 793-6900

CODE CORNER



Dear NYC ASPE Members,

Hopefully by now you've had a chance a drop by the Code Corner to see what its about. In case you haven't, this is a place to get an update into what's happening with discussions of the plumbing code committee. You have an opportunity to participate, NYC ASPE members can email me their concerns regarding particular code sections and the associated language which they believe needs to be discussed during code committee meetings.

Best Regards, Vinny Rotoli

Email: rotoliv@vfreengineering.com



**43-02 Ditmars Blvd –
2nd Fl.
Astoria, NY 11105
P: 718.729.4900
F: 718.428.0661**

Wood & Steel Tanks
Steel Structures
ASME U&R

Stay Ahead of the Curve.

Carbon Reduction

NYC Local Law 97 Mandate

- DHW HEAT PUMPS
- WASTEWATER HEAT RECOVERY



Lync by Watts "AEGIS"
CO₂ DHW Heat Pumps

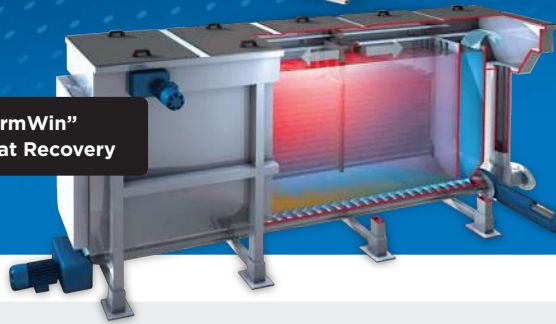

Huber "ThermWin"
Wastewater Heat Recovery

Water Conservation

Stormwater Reuse / Sustainable Practice

- DEP MANDATED CONTROLLED RELEASE RATE OF STORMWATER INTO THE CITY MAINS
- SUSTAINABLE DESIGN PRACTICES FOCUSING ON WATER CONSERVATION



Wahaso "RainyDay II"
Rain Water Harvesting System

COMPLETE SYSTEM SOLUTIONS WITH HANDS-ON SUPPORT FROM DESIGN THROUGH INSTALLATION.

Plumbing & Fire Protection Pumps

Flygt
Goulds
Peerless Pumps
Stancor

Water Heaters & Heat Recovery

AERCO
Aldrich
Envirosep
FPS DHWG Series



GE*
Hubbell Heaters & DHW Heat Pumps
Huber Wastewater Heat Recovery
Lync CO₂ DHW Heat Pumps

System Fabricators

Envirosep
FPS
SyncroFlo
VC Systems & Controls

Heat Trace & Water Detection

Raychem
Tracetek

Natural Gas & Propane-Air

Spencer Turbine

Valves, Controls, & Accessories

American Valve
Amtrol

Ekodowrol*

Firetrol
Fleetway Water Systems Controller
Flood Mitigation Systems
FPS Sub-Rig
Revere Control Systems
Singer Valves

Water Treatment & Filtration

Amiad Automatic Filters
Aquafine UV Systems
Wahaso Water Harvesting Solutions*
Triple Clear Water Solutions

*Now represented by Fleet



Call 914-835-4000

www.gafleet.com

ASPE NYC CHAPTER - SPONSOR'S DIRECTORY

Accardi Companies

79-05 Cooper Avenue
Glendale, NY 11385
Phone: 718-793-6900

www.accardicompanies.com

American Pipe & Tank Lining Co.

11-42 46th Road, Long Island City, NY 11101
T: (212) 736-6618 F:(212) 465-1734

www.americanpipeandtank.com

A.O. Smith, c/o Wales Darby Inc.

2910 Express Drive South, Islandia, NY 11749
T: (516) 585-6800 F: (516) 585-6838

Armstrong Int, Inc. c/o LPI Controls Inc.

Three Rivers, Michigan
T: (269) 279-3602

www.armstrong-intl.com

BeaconMedaes LLC

2071 5th Ave Ronkonkoma NY 11779
T: (800) 817-9297 M: (516) 521-5649

www.beaconmedaes.com

jay.dagostino@beaconmedas.com

Bradford White

725 Talamore Drive Ambler, PA 19002

L.Berenato@BradfordWhite.com

Burt Process

100 Overlook Dr. Hamden Ct.
T: (203) 287-1985

www.burtprocess.com

Charlotte Pipe c/o Platsky

298 Montrose Road, Westbury, NY 11590
T: (516) 860-5813 F: (516) 333-9446

Chicago Faucets c/o EPD

368 Wyandanch Ave., North Babylon, NY 11703
T: (631) 253-0600 F: (631) 253-0303

www.epdreps.com

Circuit Solver

5 Albertson Avenue, Albertson, NY 11507
T: (516) 625-2626 F: (516) 625-3030

Cullen

10 Memorial Drive, Neptune, NJ 07753
T: (732) 988-9600 F: (732) 988-3750

www.CullenCompany.com

Dellon Sales Company

5 Albertson Avenue, Albertson, NY 11507
T: (516) 625-2626 F: (516) 625-3030

Edwards, Platt & Deely

368 Wyandanch Ave., North Babylon, NY 11703
T: (631) 253-0600 F: (631) 253-0303

www.epdreps.com

Elkay c/o Dellon Sales Company

5 Albertson Avenue, Albertson, NY 11507
T: (516) 625-2626 F: (516) 625-3030

G.A. Fleet Associates

55 Calvert St., Harrison, NY 10528
T: (914) 835-4000 F: (914) 835-1331

Geberit

2100 S. Clearwater Dr. Des Plaines, IL 60018
T: (847) 803-5000

www.geberitnorthamerica.com/home/

Harper Control Solutions Inc.

1010 Washington Blvd, Stamford, CT 06901
T: (203) 964-1900 F: (203) 964-4900

www.HarperValves.com

Heat Timer Corp.

20 New Dutch Lane, Fairfield, NJ 07004
T: (973) 575-4004 F: (973) 575-4052

www.heat-timer.com

Highmark

49 W. 45th St., 6th Floor New York, NY 10036
T: (212) 920-4878

www.highmark.co

Holby Valve Co. Inc.

24 Ferdon Street, Newark, NJ 07105
T: (973) 465-7400 F: (973) 465-7475

www.holbyvalve.com

Isseks Bros.

298 Broome Street, New York, NY 10002
T: (212) 267-2688

www.isseks.com

Kohler

Joe Ghazarian
(215) 378-4903

joseph.Ghazarian@kohler.com

Lixil (American Standard/Grohe)

Mike Ford
(732) 628-6367

michael.Ford@lixil.com

LPI Controls

442 W 49th St, NY, NY 10019
T: (212) 244-8878

Metropolitan Industries, Inc.

37 Forestwood Dr. Romeoville, IL 60446
T: (815) 886-9200

www.metropolitanind.com

Nibco Valve Co.

1516 Middlebury St., Elkhart, IN 46515-1167
T: (973) 886-5322 F: (574) 295-3307

www.nibco.com

Olympic Plumbing

4 Aerial Way, Syosset, NY, 11791
T: (718) 528-4001

Platsky Company

298 Montrose Road, Westbury, NY 11590
T: (516) 860-5813 F: (516) 333-9446

<https://platsky.com/>

Quimby Equipment Co., Inc

159 Express St., Plainview, NY 11803
T: (516) 349-5959 F: (516) 349-0709

Rathe Associates

T: (631) 822-1200

www.ratheassociates.com

Reliable Automatic Sprinkler Co. Inc.,

103 Fairview Park Drive , Elmsford, NY 10523
T: (800) 431-1588 F: (800) 848-6051

www.reliablesprinkler.com

Rheem c/o Dellon Sales

1100 Abernathy Rd, Suite 1700 Atlanta, GA 30328
<https://www.rheem.com/>

Rich-Tomkins Company

T: (610) 859-3552

info@richtomkins.com

Rosenwach Tank Co. Inc.

43-02 Ditmars Blvd. 2nd Floor Astoria, NY 11105
T: (718) 729-4900 F: (718) 482-0661

SCHOTT North America, Inc.

2 International Drive, suite 105 Rye Brook, NY 10573
T: (914) 831-2215 F: (914) 831-2368

Sherman Engineering

1830 Country Line Road Unit 303
Huntingdon Valley, PA 19006

T: (215) 340-5300 F: (215) 340-5305

Sloan, c/o Edwards, Platt & Deely

368 Wyandanch Ave., W Babylon, NY 11703
T: (631) 253-0600 F: (631) 253-0303

Section 22 LLC

T: (732) 729-942-9444
sales@section22llc.com

Synergy Process Solutions, LLC

4610 Entrance Drive Suite H
Charlotte, NC 28273

www.pattonsmedical.com

T&S Brass & Bronze

2 Saddleback Cove, P.O. Box 1088
Traveller's Rest, SC 26990-1088

T: (864) 834-4102 F: (864) 834-3518

www.tsbrass.com

Viking Corp

Jim Dooley

(215)280-4764

jdooley@vikingcorp.com

Viega

9-03 44th Rd. Long Island City, NY 11101
T: (718) 308-6320

www.viega.us

Wales Darby Inc.

2910 Express Drive South, Islandia, NY 11749 T:
(631) 585-6800 F: (631) 585-6838

Wallace Eannace Associates

50 Newton Rd., Plainview, NY 11803
T: (516) 454-9300 F: (516) 454-9307

www.wea-inc.com

Watts, c/o Edwards, Platt & Deely

368 Wyandanch Ave., W. Babylon, NY 11703
T: (631) 253-0600 F: (631) 253-0303

Woods & Jaye Sales

33-09 37th Ave., LIC, NY 11101
T: (718) 786-8260 F: (718) 786-5393

sales@wjny.com www.wjny.com

Zurn, c/o Dellon Sales

5 Albertson Avenue, Albertson, NY 11507
T: (516) 625-2626 F: (516) 625-3030



ASPE 2024 - 2025



ASPE 2024 - 2025



ASPE 2024 - 2025